

**CONTENTS**

**CHAPTER 1 SAFETY PRECAUTIONS ..... 2**

**CHAPTER 2 PRODUCT INFORMATION ..... 4**

    2.1 Naming rules .....4

    2.2 Nameplates ..... 4

    2.3 G680/G680S Inverter Series .....5

    2.4 Dimensions of the external shape and mounting holes ..... 7

    2.5 Options ..... 11

    2.6 Brake Components Selection Guide ..... 12

**CHAPTER 3 ELECTRICAL INSTALLATION AND WIRING ..... 16**

    3.1 Electrical Installation ..... 16

    3.2 Wiring methods ..... 18

    3.3 External terminals control four different operating modes .....27

**CHAPTER 4 OPERATION AND DISPLAY ..... 29**

    4.1 Introduction to the operation and display interface ..... 29

    4.2 Organization of Inverter Function Codes ..... 31

    4.3 Function Code Viewing and Modification Methods Description .....31

    4.4 Function Code Menu Modes and Switching Instructions .....32

    4.5 Multi-Segment Speed Switch Combination Instruction Description ..... 33

**CHAPTER 5 TROUBLESHOOTING AND COUNTERMEASURES .....35**

    5.1 Fault Alarms and Countermeasures .....35

    5.2 Common faults and their treatment ..... 40

**CHAPTER 6 G680/G680S MODBUS COMMUNICATION PROTOCOL ..... 42**

**CHAPTER 7. FUNCTIONAL PARAMETERS TABLE ..... 51**

**CHAPTER 8 MOTOR CLOSED LOOP COMMISSIONING INSTRUCTIONS133**

    8.1 Asynchronous motor closed-loop commissioning instructions ..... 133

    8.2 Closed-loop commissioning instructions for permanent magnet synchronous motors ..... 134

**APPENDIX A: CARD CLASS DESCRIPTIONS ..... 135**

    A. Expansion Card Installation Instructions ..... 135

    B. Expansion card instructions ..... 136

## Chapter 1 Safety Precautions

### Security definitions





In this manual, safety precautions are divided into the following two categories.







 **DANGER:** Danger caused by failure to comply with requirements, which may result in serious injury or even death.

 **CAUTION:** Hazards caused by failure to comply with requirements may result in moderate or minor injuries and damage to equipment.

Users are requested to read this chapter carefully when installing, commissioning and servicing the system, and to be sure to operate in accordance with the safety precautions required by the contents of this chapter. If there is any injury or damage caused by illegal operation, it has nothing to do with our company.

### Security matters.

Utilization point	Security level	Entry
Pre-install	 <b>DANGER</b>	Do not install the control system if you find water in the control system, missing parts, or any parts are damaged when you open the box! Do not install if the packing list does not match the physical name!
	 <b>CAUTION</b>	It should be lifted and placed gently during handling, otherwise there is a risk of damage to the equipment! Do not use the inverter with damaged drives or defective parts, as there is a risk of injury! Do not touch the components of the control system with your hands, otherwise there is a risk of electrostatic damage!
Installation	 <b>DANGER</b>	Please install on a flame-retardant object such as metal; keep away from combustible materials. Otherwise it may cause fire! Do not unscrew the fixing bolts of the device elements, especially those marked with a red color!
	 <b>CAUTION</b>	Do not allow wire tips or screws to fall into the drive, as this causes damage to the drive! Install the drive in a location with little vibration and out of direct sunlight. When two or more inverters are placed in the same cabinet, please pay attention to the installation position to ensure the heat dissipation effect.
Wiring	 <b>DANGER</b>	The work must be carried out by a professional electrical engineer, otherwise unexpected dangers can occur! The inverter must be separated from the power supply by a circuit breaker, otherwise a fire may occur! Please make sure the power supply is in zero energy state before wiring, otherwise there is a risk of electric shock! Please correctly regulate the grounding of the inverter according to the standard, otherwise there is a danger of electric shock!

Utilization point	Security level	Entry
	 CAUTION	Never connect the input power supply to the output terminals (U, V, W) of the inverter. Pay attention to the markings on the terminals and do not connect the wrong wires! Otherwise cause damage to the drive! Never connect the braking resistor directly between the (+) and (-) terminals of the DC bus, otherwise it will cause a fire! Refer to the recommendations in the manual for the wire gauge used, otherwise accidents may occur!
Pre-power-on	 CAUTION	Please confirm whether the voltage level of the input power supply is the same as the rated voltage level of the inverter; whether the wiring position on the power supply input terminals (R, S, T) and output terminals (U, V, W) is correct; and pay attention to checking whether there is any short-circuiting phenomenon in the peripheral circuits connected with the drive, and whether the connected wiring is tightened or not, or else it will cause damage to the drive! No part of the inverter is required to be tested for voltage withstand, the product has been tested for this at the factory, otherwise it may cause accidents!
	 DANGER	The inverter must be covered before powering up, otherwise it may cause electric shock! The wiring of all peripheral accessories must comply with the instructions in this manual and be wired correctly in accordance with the circuit connection methods provided in this manual, or cause accidents!
After-power-on	 DANGER	Do not open the cover after powering up. Otherwise there is a risk of electric shock! Do not touch any input or output terminals of the inverter. Otherwise there is a danger of electric shock!
	 CAUTION	If parameter identification is required, be aware of the danger of injury during motor rotation, which may cause accidents! Do not change the inverter manufacturer's parameters arbitrarily, as this may cause damage to the equipment!
Running	 DANGER	Non-professional technicians should not test the signal during operation, as this may cause personal injury or equipment damage! Do not touch the cooling fan and discharge resistor to test the temperature, as this may cause burns!
	 CAUTION	During the operation of the inverter, you should avoid anything falling into the device, otherwise it causes damage to the device! Do not use the contactor on/off method to control the start/stop of the drive, or cause equipment damage!

### Chapter 2 Product Information

#### 2.1 Naming rules

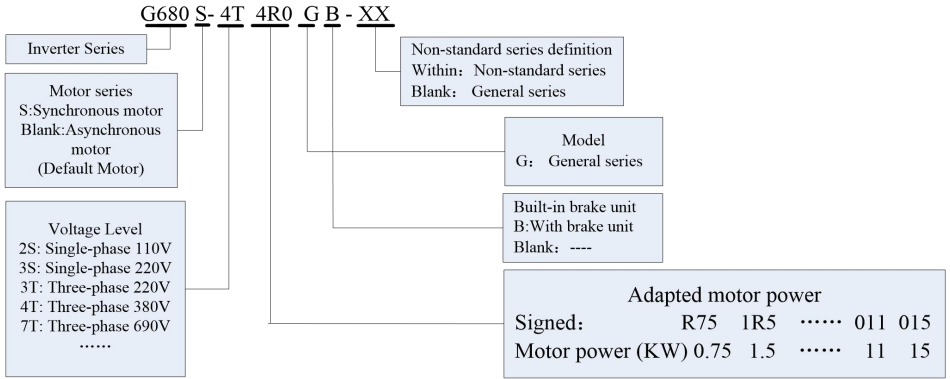

Figure 2-1. Naming Specifications

#### 2.2 Nameplates

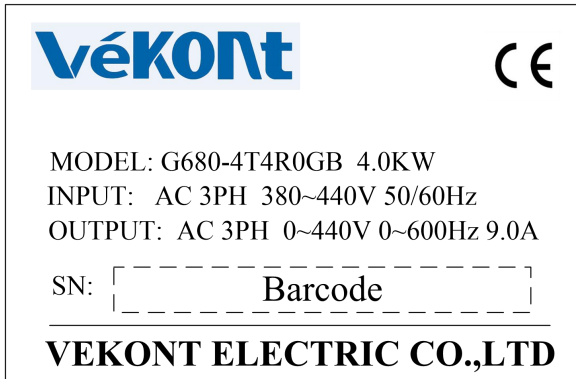

Figure 2-2.

## 2.3 G680/G680S Inverter Series

Table 2-1 G680/G680S Inverter Models and Technical Data

Description: 4T: 380V 22kW or less brake unit standard, model number with the letter "B", 30 ~ 93kW brake unit optional, model number without the letter "B", if you need, please specify when ordering, and add the letter "B" to the end of the model number. If you need, please specify when ordering and add the letter "B" after the model number.

Inverter model	Input Voltage	Input current (A)	Output current (A)	Adapted to the motor (kW)
G680/G680S-2SR4G	Single-phase 220V Scope. -15%to20%	5.4	2.3	0.4
G680/G680S-2SR75G		8.2	4.0	0.75
G680/G680S-2S1R5G		14.0	7.0	1.5
G680/G680S-2S2R2G		23.0	9.6	2.2
G680/G680S-4TR75GB	Three-phase 380V Scope. -20%to20%	3.4	2.1	0.75
G680/G680S-4T1R5GB/2R2PB		5.0/5.8	3.8/5.5	1.5/2.2
G680/G680S-4T2R2GB/4R0PB		5.8/10.5	5.5/9.0	2.2/4.0
G680/G680S-4T4R0GB/5R5PB		10.5/14.6	9.0/13.0	4.0/5.5
G680/G680S-4T5R5GB/7R5PB		14.6/20.5	13.0/17.0	5.5/7.5
G680/G680S-4T7R5GB/011PB		20.5/26.0	17.0/25.0	7.5/11.0
G680/G680S-4T011GB/015PB		26.0/35.0	25.0/32.0	11.0/15.0
G680/G680S-4T015GB/018PB		35.0/38.5	32.0/37.0	15.0/18.5
G680/G680S-4T018GB/022PB		38.5/46.5	37.0/45.0	18.5/22.0
G680/G680S-4T022GB/030PB		46.5/62.0	45.0/60.0	22.0/30.0
G680/G680S-4T030G(B)/037P(B)		62.0/76.0	60.0/75.0	30.0/37.0
G680/G680S-4T037G(B)/045P(B)		76.0/92.0	75.0/90.0	37.0/45.0
G680/G680S-4T045G(B)/055P(B)		92.0/113.0	90.0/110.0	45.0/55.0
G680/G680S-4T055G(B)/075P(B)		113.0/157.0	110.0/152.0	55.0/75.0
G680/G680S-4T075G(B)/093P(B)		157.0/180.0	152.0/176.0	75.0/93.0
G680/G680S-4T093G(B)/110P(B)		180.0/214.0	176.0/210.0	93.0/110.0
G680/G680S-4T110G/132P		214.0/256.0	210.0/253.0	110.0/132.0
G680/G680S-4T132G/160P		256.0/307.0	253.0/304.0	132.0/160.0
G680/G680S-4T160G/185P		307.0/345.0	304.0/340.0	160.0/185.0
G680/G680S-4T185G/200P		345.0/385.0	340.0/380.0	185.0/200.0
G680/G680S-4T200G/220P		385.0/430.0	380.0/426.0	200.0/220.0
G680/G680S-4T220G/250P		430.0/468.0	426.0/465.0	220.0/250.0
G680/G680S-4T250G/280P		468.0/525.0	465.0/520.0	250.0/280.0
G680/G680S-4T280G/315P		525.0/590.0	520.0/585.0	280.0/315.0
G680/G680S-4T315G/355P		590.0/665.0	585.0/650.0	315.0/355.0
G680/G680S-4T355G/400P		665.0/785.0	650.0/725.0	355.0/400.0
G680/G680S-4T400G/450P		785.0/883.0	725.0/820.0	400.0/450.0
G680/G680S-4T450G/500P		883.0/920.0	820.0/900.0	450.0/500.0
G680/G680S-4T500G/550P		920.0/1020.0	900.0/1000.0	500.0/550.0
G680/G680S-4T550G/630P		1020.0/1120.0	1000.0/1100.0	550.0/630.0
G680/G680S-4T630G/700P		1120.0/1360.0	1100.0/1320	630.0/700.0
G680/G680S-4T700G/800P		1360.0/1567.0	1320.0/1520	700.0/800.0
G680/G680S-4T800G/900P	1567.0/1763.0	1520.0/1710	800.0/900.0	
G680/G680S-4T900G/1000P	1763.0/1959.0	1710.0/1900	900.0/1000.0	

Inverter model	Input Voltage	Input current (A)	Output current (A)	Adapted to the motor (kW)
G680/G680S-4T1000G		1959.0	1900	1000
G680/G680S-2TR4GB	Three-phase 220V Scope. -15%to20%	3.4	2.1	0.4
G680/G680S-2TR75GB		5.0	3.8	0.75
G680/G680S-2T1R5GB		5.8	5.5	1.5
G680/G680S-2T2R2GB		10.5	9.0	2.2
G680/G680S-2T4R0GB		14.6	13.0	4.0
G680/G680S-2T5R5GB		26.0	25.0	5.5
G680/G680S-2T7R5GB		35.0	32.0	7.5
G680/G680S-2T011GB		46.5	45.0	11.0
G680/G680S-2T015GB		62.0	60.0	15.0
G680/G680S-2T018G		76.0	75.0	18.5
G680/G680S-2T022G		92.0	90.0	22.0
G680/G680S-2T030G		113.0	110.0	30.0
G680/G680S-2T037G		157.0	152.0	37.0
G680/G680S-2T045G		180.0	176.0	45.0
G680/G680S-2T055G		214.0	210.0	55.0
G680/G680S-2T075G		307.0	304.0	75.0
G680/G680S-2T090G		385.0	380.0	90.0
G680/G680S-2T110G		430.0	426.0	110.0
G680/G680S-2T132G		468.0	465.0	132.0
G680/G680S-2T160G		590.0	585.0	160.0
G680/G680S-2T220G	785.0	725.0	220.0	

### 2.4 Dimensions of the external shape and mounting holes

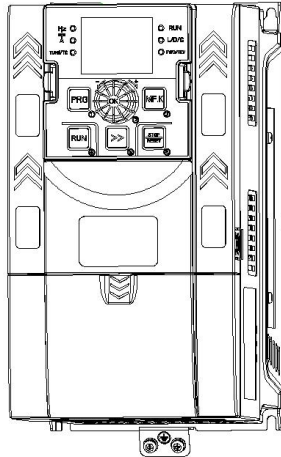

Plastic structure product outline drawing

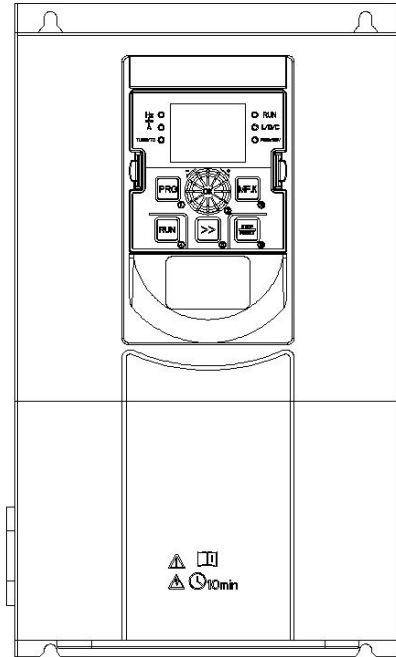

Sheet metal structure product outline drawing

Figure 2-3. Plastic and Sheet Metal Construction Product Exterior Drawing

### 2.4.2 Dimensions of G680/G680S shape and mounting holes (mm)

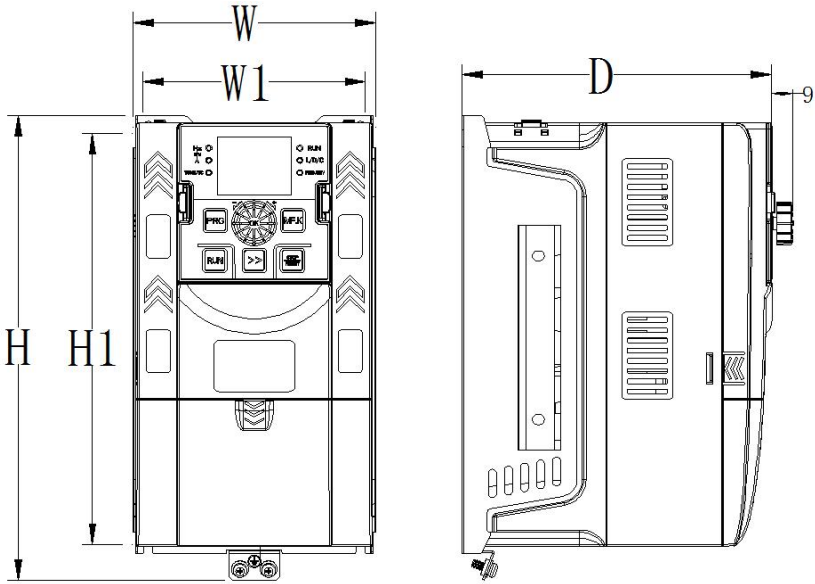

Figure 2-4. Plastic External/Mounting Dimensions for 380V 4T 11KW or less

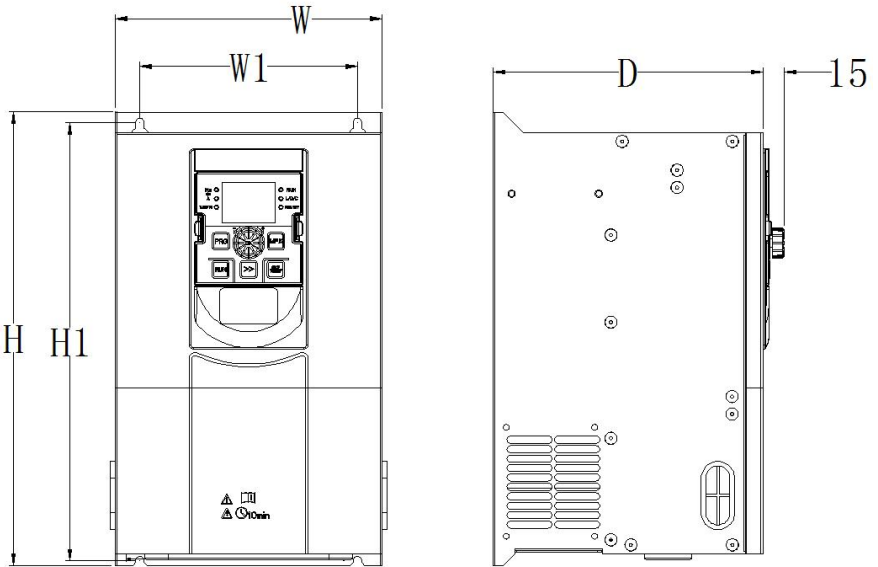

Figure 2-5. Metal External/Installation Dimensions for 380V (4T) 15~200kW

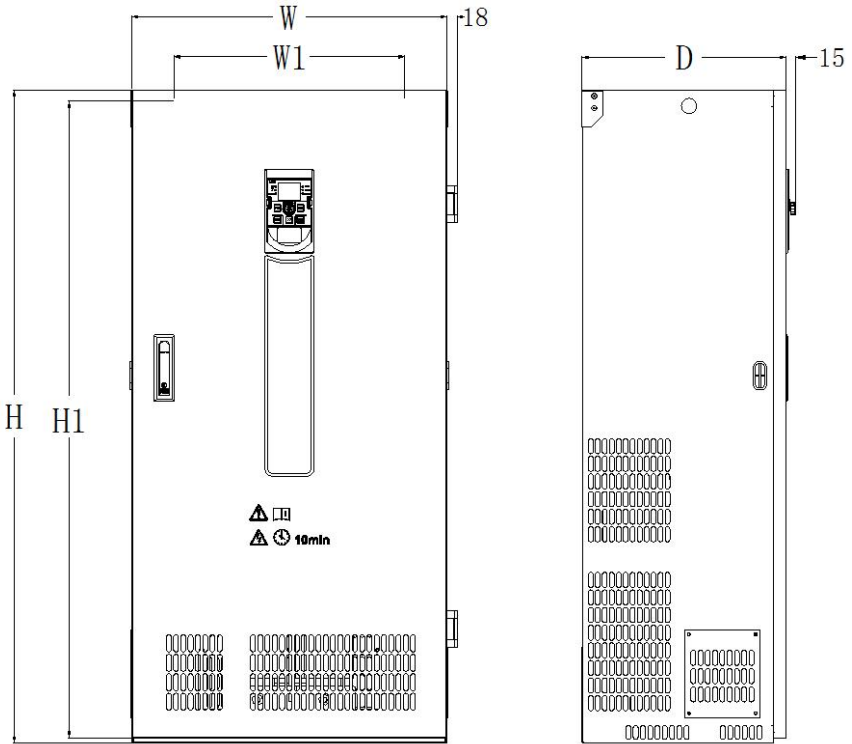

Figure 2-6. External/Mounting dimensions of inverter for 380V 220kW or more

Table 2-2 G680/G680S External Dimensions and Mounting Hole Dimensions

Inverter model	Mounting holes		Overall dimensions			Mounting aperture (mm)
	W1 (mm)	H1 (mm)	H (mm)	W (mm)	D (mm)	
G680/G680S-2SR4G	82	172	189	96	140	φ4.5
G680/G680S-2SR75G						
G680/G680S-2S1R5G						
G680/G680S-2S2R2G	104	204	227	119	155	φ4.5
G680/G680S-2S4R0GB	126	244	269.5	138	170	φ5.5
G680/G680S-2S5R5GB						
G680/G680S-4TR75GB						
G680/G680S-4T1R5GB/2R2PB	82	172	189	96	140	φ4.5
G680/G680S-4T2R2GB/4R0PB						
G680/G680S-4T4R0GB/5R5PB						
G680/G680S-4T5R5GB/7R5PB	104	204	227	119	155	φ4.5
G680/G680S-4T7R5GB/011PB	126	244	269.5	138	170	φ5.5
G680/G680S-4T011GB/015PB						
G680/G680S-4T015GB/018PB	150	302	312	184	186	φ6
G680/G680S-4T018GB/022PB	150	302	312	184	186	φ6
G680/G680S-4T022GB/030PB						

Inverter model	Mounting holes		Overall dimensions			Mounting aperture (mm)
	W1 (mm)	H1 (mm)	H (mm)	W (mm)	D (mm)	
G680/G680S-4T030G/037P	160	342	353	210	200	φ6
G680/G680S-4T037G/045P	200	426	440	257	200	φ7
G680/G680S-4T045G/055P						
G680/G680S-4T055G/075P	245	514	530	310	255	φ10
G680/G680S-4T075G/093P						
G680/G680S-4T093G/110P	290	539	555	350	262	φ10
G680/G680S-4T110G/132P						
G680/G680S-4T132G/160P	320	682	700	430	290	φ10
G680/G680S-4T160G/185P						
G680/G680S-4T185G/200P	360	740	770	470	318	φ12
G680/G680S-4T200G/220P						
G680/G680S-4T220G/250P	380	1048	1075	520	338	φ12
G680/G680S-4T250G/280P						
G680/G680S-4T280G/315P	500	1238	1270	630	425	φ12
G680/G680S-4T315G/355P						
G680/G680S-4T355G/400P	500	1328	1360	740	410	φ14
G680/G680S-4T400G/450P						
G680/G680S-4T450G/500P						
G680/G680S-4T500G/550P						
G680/G680S-4T550G/600P						
G680/G680S-4T630G/700P	Floor standing cabinet type		1750	1060	482	-
G680/G680S-4T700G/800P						
G680/G680S-4T800G/900P	Floor-mounted cabinets Monoblocs		2100	1730	650	-
G680/G680S-4T900G/1000P						
G680/G680S-4T1000G						
G680/G680S-2TR4GB	82	172	189	96	140	φ4.5
G680/G680S-2TR75GB						
G680/G680S-2T1R5GB						
G680/G680S-2T2R2GB	104	204	227	119	155	φ4.5
G680/G680S-2T4R0GB						
G680/G680S-2T5R5GB	126	244	269.5	138	170	φ5.5
G680/G680S-2T7R5GB	150	302	312	184	186	φ6
G680/G680S-2T011GB						
G680/G680S-2T015GB	160	342	353	210	200	φ6
G680/G680S-2T018G	200	426	440	257	200	φ7
G680/G680S-2T022G						
G680/G680S-2T030G	245	514	530	310	255	φ10
G680/G680S-2T037G						
G680/G680S-2T045G	290	539	555	350	262	φ10
G680/G680S-2T055G						
G680/G680S-2T075G	320	682	700	430	290	φ10
G680/G680S-2T090G	360	973	1000	470	318	φ12
G680/G680S-2T110G	380	1048	1075	520	338	φ12
G680/G680S-2T132G						
G680/G680S-2T160G	500	1238	1270	630	425	φ12
G680/G680S-2T220G	500	1328	1360	740	410	φ14

2.4.3 External dimensions of keyboard with/without tray (mm)

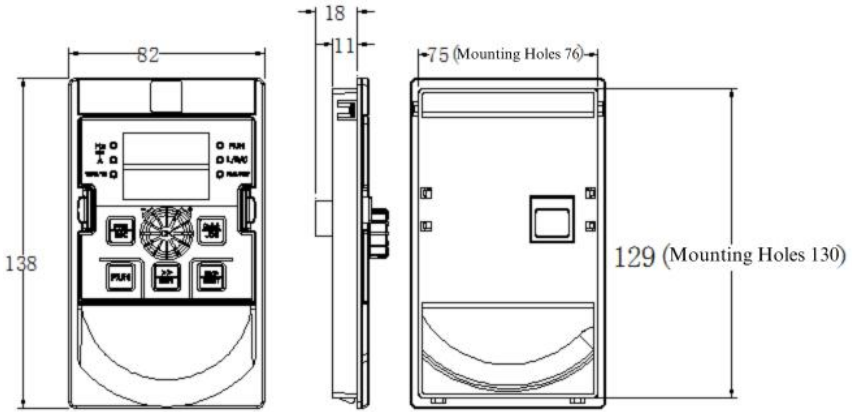

Figure 2-8.1 External dimensions of keyboard with tray (Mounting hole size 76\*130)

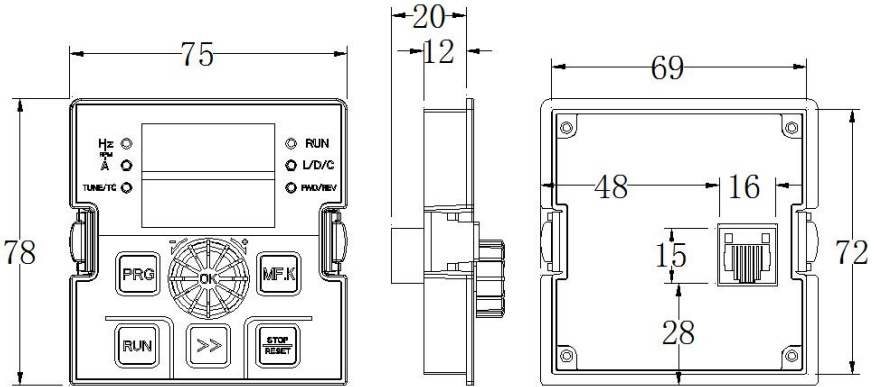

Figure 2-9.1 External dimensions of keyboard without tray (Mounting hole size 69\*72)

2.5 Options

For detailed functions and instructions on the use of options, see the relevant option descriptions.

If any of the above options are required, please specify when ordering.

Table 2-6 G680/G680S Inverter Options

Name	Model	Function	Remarks
------	-------	----------	---------

Built-in brake unit	Mame followed by "B"	Energy consumption for braking	4T:380V 22kW or less built-in brake unit is standard, 4T:380V 30-93kW built-in brake unit is optional.
External LED operation panel	G680-LED2	External LED display and operating keypad	G Series General Purpose RJ45 interface
External LCD operation panel	G680 -LCD	External LCD display and operating keypad	RJ45 interface
Extension cables	G680-CFB	Standard 8-pole network cable, can be connected with G680/G680S-LED, 500-LCD	Available in 4 sizes: 1m, 2m, 5m and 10m.
PROFIBUS-DP Bus Cards	G680PFS	Realization of PROFIBUS-DP bus communication functions	/
Open Collector Input PGO Card	G680-PGO	Open collector PG card with 1:1 split open collector signal outputs	Suitable for 15V supply, push-pull or open collector output encoders
Differential signal input to PGD card	G680-PGD	Differential signal input PG card for asynchronous/synchronous machines with 1:1 split open collector signal outputs	Long drive PG card (must use 5V differential signal encoder)
Rotary Transformer Input PGR Card	G680-PGR	Rotary Transformer Input PG Card for Asynchronous/Synchronous Machines with 1:1 Split Differential Signal Outputs	Suitable for resolver encoders
Sine-cosine PGS card	G680-PGS	PG card with sine/cosine input for asynchronous/synchronous machines	Suitable for SIN/COS (sine-cosine) encoders type ERN1387
Three-way temperature detection card	G680-3TEMP	Detection of external motor temperature or equipment temperature and over-temperature protection.	For PT100 or KTY84 temperature sensors
If you need other function modules to extend the function (e.g. I/O card, PG card, EPS card, etc.), please use G680 series inverter and specify the function module card when ordering.			

## 2.6 Brake Components Selection Guide

The following table 2-5 is the guidance data, the user can choose different resistor resistance value and power according to the actual situation, (but the resistance value must not be less than the recommended value in the table, the power can be large.) The selection of braking resistor needs to be determined according to the power generated by the motor in the actual application system, which is related to the inertia of the system, deceleration time, and the energy of the bit energy load, etc., and needs to be selected by the customer according to the actual situation. The larger the inertia of the system, the shorter the deceleration time required, and the more frequent the braking, the larger the power and smaller the resistance value of the braking resistor needs to be selected.

### 2.6.1 Selection of resistance value

When braking, the regenerative energy of the motor is almost entirely consumed in the braking resistor. Can be based on the formula:  $U \cdot U / R = P_b$

U---- braking voltage for stabilised braking of the system (varies from system to system, generally 700V for 380VFC systems)

P<sub>b</sub>---- Braking power

### 2.6.2 Power selection of the braking resistor

Theoretically, the power of the braking resistor is the same as the braking power, but considering the derating is 70%. Can be based on the formula:  $0.7 \cdot P_r = P_b \cdot D$

P<sub>r</sub>---- Power of the resistor

D---- Braking frequency (proportion of the regeneration process to the total working process), generally taken as 10%. Please refer to the following table.

Application industries	The elevator	Unwind and unwind	Centrifuges	Occasional braking loads
Proportion	20% to 30%	20 to 30%	50% to 60%	5%

Table 2-7 G680 inverter braking component selection table (G680S synchronous motor drive series in the G680 series based on the reference to the previous inverter power selection, that is, 4.0kW refer to 5.5kW selection)

Inverter Model	Braking torque 150%, 5S recommended resistor resistance, power and brake unit type	Braking torque 100%, 15S Recommended resistance value, power and brake unit type	Braking torque 50%, 15S Recommended resistance value, power and brake unit type
G680-2SR4G	≥220Ω, 100W Brake unit option	≥300Ω, 80W Brake unit option	≥300Ω, 80W Brake unit option
G680-2SR75G	≥200Ω, 100W Brake unit option	≥200Ω, 100W Brake unit option	≥300Ω, 80W Brake unit option
G680-2S1R5G	≥100Ω, 200W Brake unit option	≥200Ω, 100W Brake unit option	≥300Ω, 80W Brake unit option
G680-2S2R2GB	≥75Ω, 0.4kW Brake unit built-in	≥130Ω, 0.2kW Brake unit built-in	≥150Ω, 0.2kW Brake unit built-in

Inverter Model	Braking torque 150%, 5S recommended resistor resistance, power and brake unit type	Braking torque 100%, 15S Recommended resistance value, power and brake unit type	Braking torque 50%, 15S Recommended resistance value, power and brake unit type
G680-2S4R0GB	≥60Ω, 0.3kW Brake unit built-in	≥75Ω, 0.4kW Brake unit built-in	≥100Ω, 0.2kW Brake unit built-in
G680-2S5R5GB	≥40Ω, 0.8kW Brake unit built-in	≥50Ω, 1.5kW Brake unit built-in	≥60Ω, 0.3kW Brake unit built-in
G680-4TR75GB	≥300Ω, 0.2kW Brake unit built-in	≥300Ω, 0.2kW Brake unit built-in	≥300Ω, 0.2kW Brake unit built-in
G680-4T1R5GB	≥150Ω, 0.3kW Brake unit built-in	≥220Ω, 0.25kW Brake unit built-in	≥300Ω, 0.2kW Brake unit built-in
G680-4T2R2GB	≥100Ω, 0.4kW Brake unit built-in	≥130Ω, 0.4kW Brake unit built-in	≥150Ω, 0.3kW Brake unit built-in
G680-4T4R0GB	≥75Ω, 0.5kW Brake unit built-in	≥100Ω, 0.4kW Brake unit built-in	≥130Ω, 0.4kW Brake unit built-in
G680-4T5R5GB	≥60Ω, 0.5kW Brake unit built-in	≥75Ω, 0.5kW Brake unit built-in	≥100Ω, 0.4kW Brake unit built-in
G680-4T011GB	≥40Ω, 1.0kW Brake unit built-in	≥50Ω, 0.7kW Brake unit built-in	≥60Ω, 0.5kW Brake unit built-in
G680-4T015GB	≥30Ω, 1.2kW Brake unit built-in	≥40Ω, 1.0kW Brake unit built-in	≥50Ω, 0.7kW Brake unit built-in
G680-4T018GB	≥24Ω, 2kW Brake unit built-in	≥30Ω, 1.2kW Brake unit built-in	≥40Ω, 1.0kW Brake unit built-in
G680-4T022GB	≥13.6Ω, 3.7kW Brake unit built-in	≥30Ω, 1.2kW Brake unit built-in	≥40Ω, 1.0kW Brake unit built-in
G680-4T030GB	≥13.6Ω, 3.7kW Brake unit built-in option	≥24Ω, 2kW Brake unit built-in option	≥30Ω, 2kW Brake unit built-in option
G680-4T037G	≥10Ω, 4.5kW Brake unit built-in option	≥24Ω, 2kW Brake unit built-in option	≥24Ω, 2kW Brake unit built-in option
G680-4T045G	≥10Ω, 4.5kW Brake unit built-in option	≥13.6Ω, 3.7kW Brake unit built-in option	≥24Ω, 2kW Brake unit built-in option
G680-4T055G	≥6.8Ω, 8.0kW Brake unit built-in option	≥10Ω, 4.5kW Brake unit built-in option	≥13.6Ω, 3.7kW Brake unit built-in option
G680-4T075G	≥2*(6.8Ω, 8.0kW)	≥6.8Ω, 8.0kW	≥6.8Ω, 8.0kW
G680-4T093G	≥3*(6.8Ω, 8.0kW)	≥2*(6.8Ω, 8.0kW)	≥2*(6.8Ω, 8.0kW)
G680-4T110G			
G680-4T132G			
G680-4T160G			

Inverter Model	Braking torque 150%, 5S recommended resistor resistance, power and brake unit type	Braking torque 100%, 15S Recommended resistance value, power and brake unit type	Braking torque 50%, 15S Recommended resistance value, power and brake unit type
G680-4T185G	BR500-4T315	BR500-4T200	BR500-4T200
G680-4T200G			
G680-4T220G			
G680-4T250G	≥3* (6.8Ω, 8.0kW)	≥2* (6.8Ω, 8.0kW)	≥2* (6.8Ω, 8.0kW)
G680-4T280G	BR500-4T315	BR500-4T315	BR500-4T315
G680-4T315G			
G680-4T355G			
G680-4T400G	≥5* (6.8Ω, 8.0kW)	≥4* (6.8Ω, 8.0kW)	≥3*(6.8Ω, 8kW)
G680-4T450G	BR500-4T630	BR500-4T450	BR500-4T450
G680-B4T500G			
G680-B4T550G	≥6* (6.8Ω, 8.0kW)	≥4* (6.8Ω, 8.0kW)	≥4* (6.8Ω, 8kW)
G680-4T630G	BR530-4T630	BR530-4T630	BR530-4T630
G680-4T700G			
G680-4T800G			
G680-4T900G	≥8* (6.8Ω, 8.0kW)	≥6* (6.8Ω, 8.0kW)	≥6* (6.8Ω, 8kW)
G680-4T1000G	BR530-4T630	BR530-4T630	BR530-4T630

### Attention:

1. The brake resistor resistance can not less than the recommended resistance value in the table.
2. Table ×2 indicates that two groups of braking resistors are used in parallel. Table ×3 indicates that three groups of braking resistors are used in parallel, and so on;
3. Inverter model name followed by "B" for the standard built-in braking unit model inverter. Otherwise without built-in braking unit. Choose the corresponding braking unit model according to its braking torque.
4. 30~93 kW G-type mechanism braking unit is built-in optional. Please specify when ordering if necessary. The standard configuration does not come with a braking unit;
5. The 5S,15S listed in the table refers to the continuous braking time.

# Chapter 3 Electrical Installation and Wiring

## 3.1 Electrical Installation

### 3.1.1 Selection guidance for peripheral electrical components

This section of the inverter peripheral electrical components selection guide is mainly based on the G-type machine as an example, if you are used as a P-type machine, please refer to the G-type machine with the same power section electrical components selection. For example, if G680/G680S-4T4R0GB/5R5PB is used as a 5.5kW P-type machine, please refer to G680/G680S-4T5R5GB.

Table 3-1 G680/G680S peripheral electrical components selection guide

Inverter model	Blanking (MCCB) (A)	Contactor (A)	Input side main circuit conductor (mm <sup>2</sup> )	Output side main circuit conductor (mm <sup>2</sup> )	Control circuit wire (mm <sup>2</sup> )	Ground wire (mm <sup>2</sup> )
G680/G680S-2SR4G	10	9	0.75	0.75	0.5	2.5
G680/G680S-2SR75G	16	12	0.75	0.75	0.5	2.5
G680/G680S-2S1R5G	25	18	1.5	1.5	0.5	2.5
G680/G680S-2S2R2G	32	25	2.5	2.5	0.5	2.5
G680/G680S-2S4R0GB	50	40	4	4	0.5	4
G680/G680S-2S5R5GB	80	63	4	4	0.5	4
G680/G680S-4TR75GB	6	9	0.75	0.75	0.5	2.5
G680/G680S-4T1R5GB	10	9	0.75	0.75	0.5	2.5
G680/G680S-4T2R2GB	10	9	0.75	0.75	0.5	2.5
G680/G680S-4T4R0GB	16	16	2.5	2.5	0.75	2.5
G680/G680S-4T5R5GB	20	18	2.5	2.5	0.75	2.5
G680/G680S-4T7R5GB	32	25	4.0	4.0	1.0	4
G680/G680S-4T011GB	50	32	4.0	4.0	1.0	6
G680/G680S-4T015GB	63	40	6.0	6.0	1.0	6
G680/G680S-4T018GB	63	40	10	10	1.0	10
G680/G680S-4T022GB	80	50	10	10	1.0	16
G680/G680S-4T030G	100	65	16	16	1.0	16
G680/G680S-4T037G	125	80	25	25	1.0	25
G680/G680S-4T045G	160	115	35	35	1.0	25
G680/G680S-4T055G	160	150	50	50	1.0	25
G680/G680S-4T075G	225	170	70	70	1.0	25
G680/G680S-4T093G	250	205	95	95	1.0	25
G680/G680S-4T110G	315	245	120	120	1.0	25
G680/G680S-4T132G	350	300	120	120	1.0	25
G680/G680S-4T160G	400	400	150	150	1.0	25
G680/G680S-4T185G	500	410	185	185	1.0	25
G680/G680S-4T200G	500	410	185	185	1.0	25
G680/G680S-4T220G	630	475	240	240	1.0	25
G680/G680S-4T250G	630	475	2×120	2×120	1.0	25
G680/G680S-4T280G	700	620	2×120	2×120	1.0	25
G680/G680S-4T315G	900	700	2×150	2×150	1.0	35
G680/G680S-4T355G	1000	800	2×185	2×185	1.0	35
G680/G680S-4T400G	1250	900	2×240	2×240	1.0	35
G680/G680S-4T450G	1250	1000	2×240	2×240	1.0	35
G680/G680S-4T500G	1720	1500	3×183	3×183	1.5	35

Inverter model	Blanking (MCCB) (A)	Contactor (A)	Input side main circuit conductor (mm <sup>2</sup> )	Output side main circuit conductor (mm <sup>2</sup> )	Control circuit wire (mm <sup>2</sup> )	Ground wire (mm <sup>2</sup> )
G680/G680S-4T550G	1900	1500	3×240	3×240	1.5	35
G680/G680S-4T630G	2200	1650	3×240	3×240	1.5	35
G680/G680S-4T700G	2500	1360.0	4×240	4×240	1.5	50
G680/G680S-4T800G	2500	1567.0	4×240	4×240	1.5	50
G680/G680S-4T900G	3000	1763.0	5×240	5×240	1.5	50
G680/G680S-4T1000G	3200	1959.0	5×240	5×240	1.5	50
G680/G680S-2TR4GB	6	9	2.5	2.5	1.5	2.5
G680/G680S-2TR75GB	10	9	2.5	2.5	1.5	2.5
G680/G680S-2T1R1GB	10	9	2.5	2.5	1.5	2.5
G680/G680S-2T2R2GB	20	12	2.5	2.5	1.5	4
G680/G680S-2T4R0GB	32	25	4	4	1.5	4
G680/G680S-2T5R5GB	40	32	4.0	4.0	1.5	6
G680/G680S-2T7R5GB	50	40	6.0	6.0	1.5	6
G680/G680S-2T011GB	63	50	10	10	1.5	16
G680/G680S-2T015GB	100	65	16	16	1.5	16
G680/G680S-2T018G	100	80	25	25	1.5	25
G680/G680S-2T022G	125	115	35	35	1.5	25
G680/G680S-2T030G	160	150	50	50	1.5	25
G680/G680S-2T037G	225	170	70	70	1.5	25
G680/G680S-2T045G	250	205	95	95	1.5	25
G680/G680S-2T055G	315	245	120	120	1.5	25
G680/G680S-2T075G	500	400	150	150	1.5	25
G680/G680S-2T090G	630	500	240	240	1.5	25
G680/G680S-2T110G	800	630	150*2	150*2	1.5	25
G680/G680S-2T130G	800	630	150*2	150*2	1.5	25
G680/G680S-2T160G	1000	800	240*2	240*2	1.5	35
G680/G680S-2T220G	1200	1000	185*3	325*2	1.5	35

### 3.1.2 Instructions for the use of peripheral electrical components

Table 3-3 Instructions of the peripheral electrical components of G680/G680S

Accessory Name	Mounting position	Functional Description
Circuit breaker	The front-end of the input circuit	Disconnect the power supply in case of downstream equipment is over current.
Contactor	Between the circuit breaker and the inverter input side	Power-on and power-off operation of the inverter. Frequent power-on/power-off operation (more than 2 times per minute) on the inverter or direct start shall be avoided.
AC input reactor	Input side of the inverter	1) Improve the power factor of the input side. 2) Eliminate the high order harmonics of the input side effectively, and prevent other equipment from damaging due to voltage waveform deformation. 3) Eliminate the input current unbalance due to the unbalance among the phase of input.

Accessory Name	Mounting position	Functional Description
DC reactor	DC reactor is optional for 75KW~ 132KW A series inverter, but standard for the 160KW above.	1) Improve the power factor of the input side. 2) Eliminate the high order harmonics of the input side effectively, and prevent other equipment from damaging due to voltage waveform deformation.
EMC input filter	Input side of the inverter	1) Reduce the external conduction and radiation interference of the inverter; 2) Reduce the conduction interference flowing from the power end to the inverter, thus improving the anti-interference capacity of the inverter.
AC output reactor	Between the inverter output side and the motor, close to the inverter	The inverter output side generally has higher harmonic. Armonics will cause resonance in the circuit and bring in the following results: 1) Degrade the motor insulation performance and damage the motor for the long run. 2) Generate large leakage current and cause frequent inverter protection action. 3) In general, if the distance between the inverter and the motor exceeds 100 meters, output AC reactor shall be installed.

### 3.2 Wiring methods

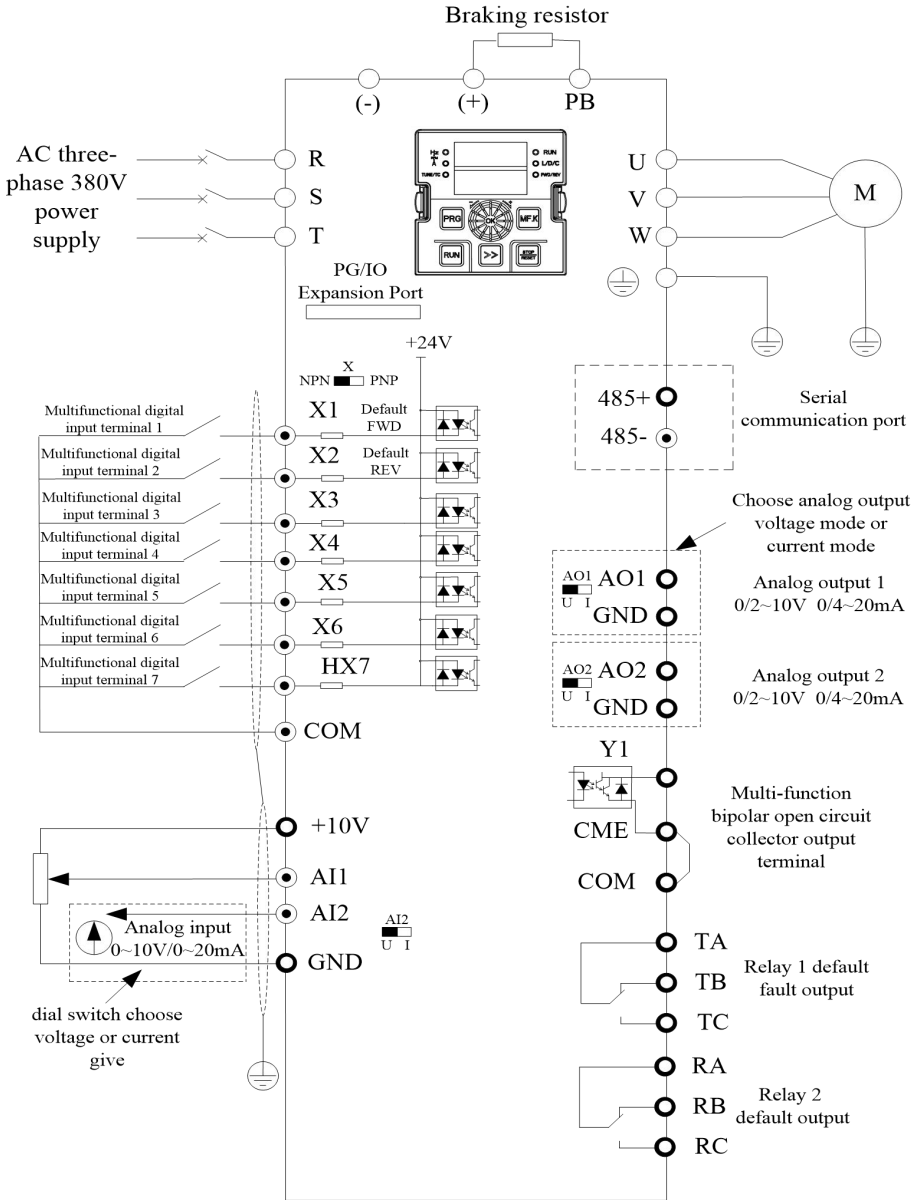

Figure 3-2. 3-phase 380V 0.75-30kW (4T:380V) and single-phase 220V (2S) 5.5kW or less (input connected to R T) Inverter Wiring Diagrams

Note: Digital input terminal X jumper switch factory default NPN mode (i.e. X short COM is effective), AI2,AO1,AO2 jumper switch factory default voltage mode.

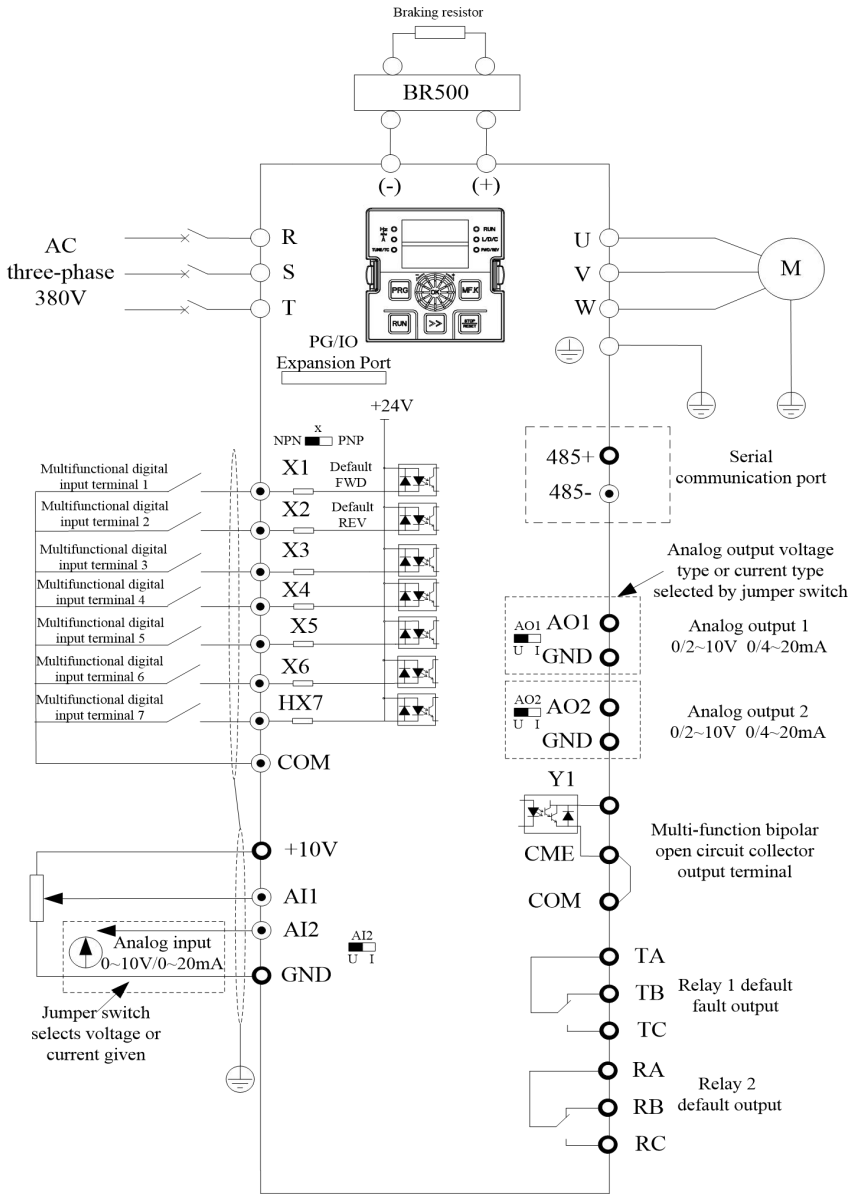

Figure 3-3. 3-phase 380V 37 ~ 75 kW (4T:380V) without brake unit function wiring diagram

Note: Digital input terminal X jumper switch factory default NPN mode (i.e. X short COM is valid), AI2,AO1,AO2 jumper switch factory default voltage mode. G680/G680S series 37~110kW brake unit part of the optional functions, if necessary, please specify when ordering, the wiring diagram of the optional brake unit function refer to Figure 3-2.

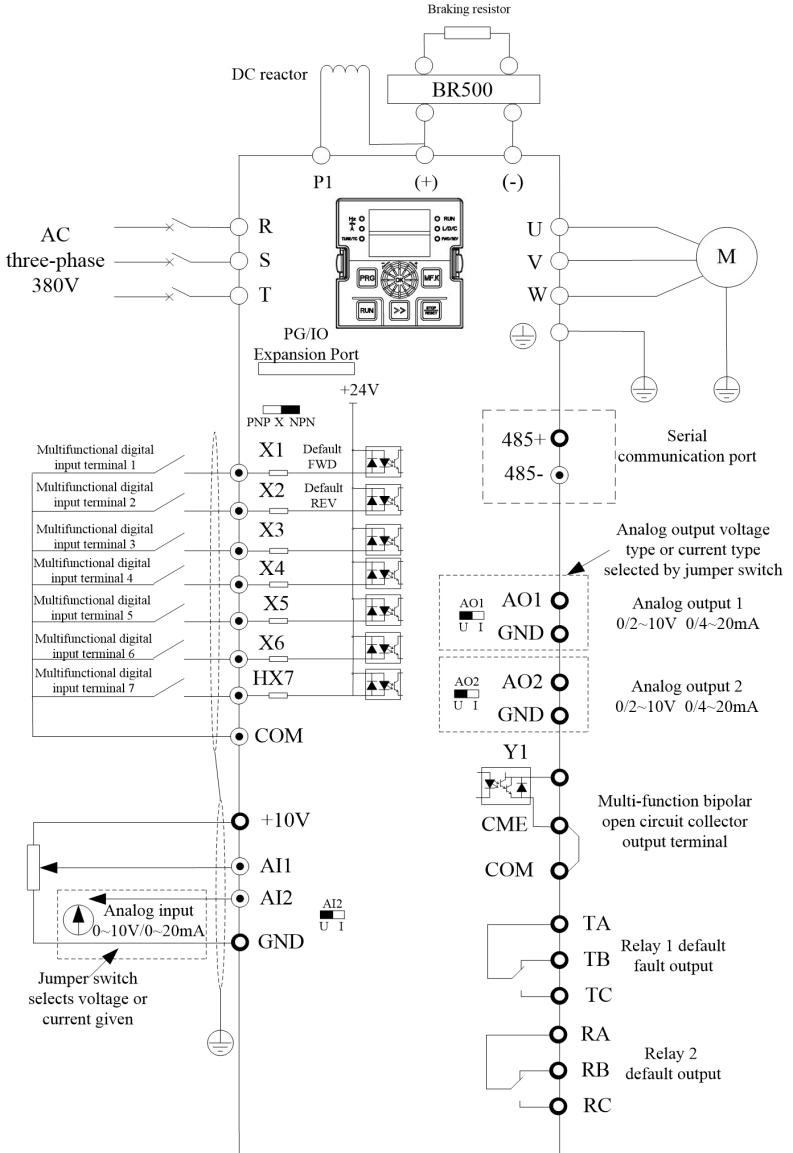



Figure 3-4. 3-Phase 380V 93kW (4T:380V) and Above 3-Phase Inverter Wiring Diagrams

Note: Digital input terminal X jumper switch factory default NPN mode (i.e. X short COM is valid), AI2,AO1,AO2 jumper switch factory default voltage mode. G680/G680S (4T:380V) 93~132kW external DC reactor optional, 220kW (including 220kW) or above built-in DC reactor standard.

### 3.2.1 Main circuit terminals and wiring

Single-phase inverter main circuit terminal description

Terminal marking	Name	Explanation
L, N	Single-phase power input terminals	single-phase 220 V AC power connection point
P(+), (-)	DC bus positive and negative terminals	Common DC bus input point
P(+), PB	Brake resistor connection terminals	Connect the braking resistor
U, V, W	Output terminals	Connecting a three-phase motor
	Ground terminal	Ground terminal

Three-phase inverter main circuit terminal description.

terminal marking	Name	Explanation
R, S, T	Three-phase power input terminals	AC input three-phase power connection point
P(+), (-)	DC bus positive and negative terminals	Common DC bus input point
P(+), PB	Brake resistor connection terminals	Braking resistor connection point for 220V up to 7.5kW, for other voltage levels up to 18.5kW
U, V, W	Inverter output terminals	Connecting a three-phase motor
	Ground terminal	Ground terminal

**Wiring Precautions.**

**Input power supply L, N or R, S, T :**

There is no phase sequence requirement for the wiring of the input side of the inverter.

**DC bus P(+),(-) :**

Pay attention to the DC bus P (+), (-) terminals have residual voltage just after the power outage, must wait for the power indicator on the drive board off, and confirm the power outage for 10 minutes before wiring operation, otherwise there is a risk of electric shock.

The wiring length of the brake unit should not exceed 10 m. Twisted-pair or close-twisted parallel wiring should be used.

Do not connect the braking resistor directly to the DC bus, which may cause damage to the inverter or even fire.

**Brake resistor connection terminals P(+), PB**

Refer to the recommended values for braking resistor selection and the wiring distance should be less than 5 m. Otherwise, the inverter may be damaged.

**Inverter Output Side U, V, W .**

Capacitors or surge absorbers should not be connected to the output side of the inverter, otherwise it will cause frequent protection or even damage to the inverter.

If the motor cable is too long, for the influence of the distribute capacitance, it's easily to have electrical resonance, causing the damage of the insulation or large leakage current which make the inverter over-current protection. If the length of motor cable is more than 100m, a AC

output reactor should be installed near the inverter.

Ground terminal  ON:

The terminal must be reliably grounded, and the resistance value of the grounding wire must be less than 0.1 Ω. Otherwise, it will lead to abnormal operation or even damage of the equipment.

Do not connect the ground terminal, the  and power supply zero wire N terminals are shared.

### 3.2.2 Control terminals and wiring

The control circuit terminal arrangement is shown below:

10V	AI1	AI2	485-	X1	X2	X3	X4	X5	COM	RA	RB	RC
GND	AO1	AO2	485+	X6	HX7	COM	CME	Y1/FM	24V	TA	TB	TC

Three-phase 380V (4T) 4.0kW and single-phase 220V (2S) 2.2kW or more

10V	AI1	AI2	X1	X2	X3	X7	COM	TA	TB	TC
GND	AO1	485+	485-	CME	COM	Y1	24V			

Three-phase 380V (4T) 2.2kW and single-phase 220V (2S) 1.5kW or less

#### Description of control terminal functions:

Table 3-4 G680/G680S Inverter Control Terminal Function Description

Category	Terminal	Terminal name	Functional description
Power source	+10V-GND	External +10V power supply	Provide +10V external power supply, maximum output current: 10mA Generally used as an external potentiometer power supply, potentiometer resistance range: 1 ~ 5kΩ
	24V-COM	External +24V power supply	Provide +24V external power supply, generally used as the working power supply of digital input/output terminals and the power supply of external sensors. Maximum output current:200mA
Analog input	AI1-GND	Analog input terminal 1	1. Input voltage range:DC0~10V 2. Input impedance:100KΩ
	AI2-GND	Analog input terminal 2	1. Input range: DC0~10V/4~20mA, selected by the J6 (AI2) jumper switch on the control board, factory voltage mode. Input impedance: 100kΩ for voltage input, 500Ω for current input.
Digital input	DI1(X1)-COM	Digital Input 1	1. Optical coupled isolation, compatible with bipolar input, switching by X (J5) jumper switch, factory NPN mode 2. Input impedance:3.3kΩ 3. Voltage range at level input:9~30V 4. HX7 can be used as a high-speed input port. 5. Three-phase 380V (4T) 2.2kW following four X terminals.
	DI2(X2)-COM	Digital Input 2	
	DI3(X3)-COM	Digital Input 3	
	DI4(X4)-COM	Digital Input 4	
	DI5(X5)-COM	Digital Input 5	

Category	Terminal	Terminal name	Functional description
	DI6(X6)-COM	Digital Input 6	
	HDI7(HX7)-COM	Digital Input 7	
Analog output	AO1-GND	Analog Output 1	The voltage or current output is determined by the J3,J4 jumper switches on the control board respectively. Output voltage range:0~10V Output current range:0~20mA or 4-20mA.
	AO2-GND	Analog Output 2	
Digital output	Y1-CME	Digital Output 1	Optical coupled isolated, bipolar open collector output (OC gate output) Output voltage range:0~24V Output current range:0~50mA Note: The digital output ground CME and digital input ground COM are internally isolated, but CME and COM have been externally shorted at the factory (at this time Y1 is driven by +24V by default). When Y1 wants to be driven by external power supply, CME and COM must be disconnected from the external short connection.
Communication interface	485+ -485-	Modbus communication interface	Modbus communication interface, can be selected by dip switch CN4 whether communication matching resistor is required. For Profibus communication function, please select G700 series inverter and choose Profibus DP card.
Relay Output 1	TA-TB	Normally closed terminals	Contact drive capability: AC250V, 3A, COSφ=0.4。 DC30V, 3A
	TA-TC	Open the terminals regularly	
Relay Output 2	RA-RB	Enclosed terminals	Contact drive capability: FC250V, 3A, COSφ=0.4。 DC30V, 3A
	RA-RC	Opened terminals	
Keyboard interface	CN6	External Keyboard Interface	External keyboard, parameter copy keyboard interface, take out the bidirectional crystal head, you can use the standard network cable (network cable wire sequence corresponds to one by one) for the extension.
expansion port (computing)	J10	External Function Expansion Interface	Mainly used for PG card, IO card or bus function card expansion

Signal input terminal wiring instructions:

**AI analogue input terminal:**

Because the weak analogue voltage signal is particularly vulnerable to external interference, it is generally necessary to use shielded cables, and the wiring distance is as short as possible, not more than 20 m, as shown in Figure 3-7. In some analogue signals are subjected to serious interference occasions, the analogue signal source side needs to be added to the filter capacitor or ferrite core.

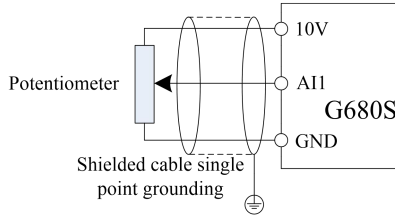
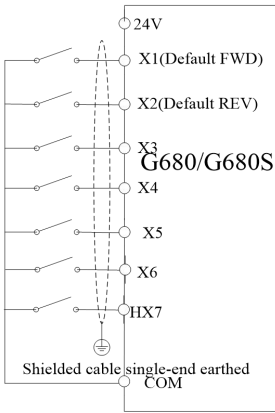

Figure 3-10. Analogue Input Terminal Wiring Schematic

X digital input terminals:

X terminal connection Mode 1 (Default) : DI dial switch in NPN mode and without external power supply



X terminal connection Mode 2: DI dial switch in NPN mode and with external power supply

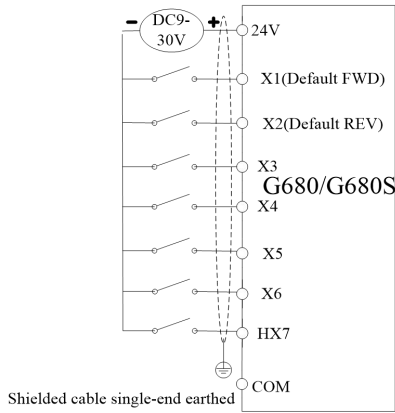

X terminal connection Mode 3: DI dial switch in PNP mode and without external power supply

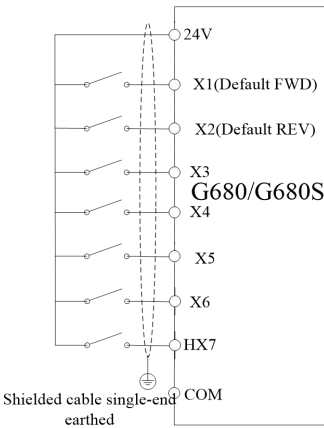

X terminal connection Mode 4: DI dial switch in PNP mode and with external power supply

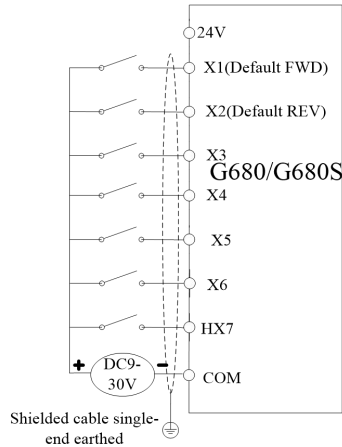

Figure 3-11. Digital Input Terminal Wiring Diagram in Four Different Modes

Shielded cables are generally required and wiring distances are kept as short as possible, not exceeding 20 meters.

When an active drive is selected, the necessary filtering measures for the crosstalk of the power supply are required.

It is recommended to use the contact control method.

**Y1 digital output terminal:**

When the digital output terminals need to drive the relay, absorbent diodes should be added on both sides of the relay coil, and the driving capacity should not be greater than 50mA.

otherwise, it is easy to cause damage to the DC 24V power supply.

Note: Be sure to install the polarity of the absorber diode correctly, as shown in Figure 3-12, otherwise the DC 24V power supply will be burned out immediately when there is output from the digital output terminals.

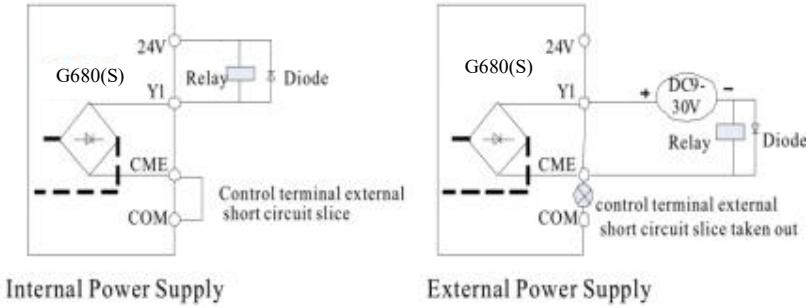

Figure 3-12. Digital output terminal Y1 wiring diagram

### 3.3 External terminals control four different operating modes

**3.3.1 Two-phase operation mode 1 (F6-11=0 default):** This mode is the most commonly used two-wire mode. The direction of the motor's rotation is determined by the FWD (default X1 terminal) and REV (default X2 terminal) terminal commands.

K1	K2	Running Command
0	0	STOP
1	0	Forward rotation
0	1	Reversal
1	1	STOP

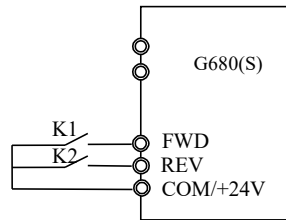

Figure3-13 Two-phase operation mode 1

**3.3.2 Two-phase operation mode 2 (F6-11=1):** The FWD terminal (defaulted to X1 when shipped) serves as the enable terminal in this mode, while the direction is determined by the state of REV terminal (defaulted to X2 when shipped).

K1	K2	Running Command
0	0	STOP
0	1	STOP
1	0	Forward rotation
1	1	Reversal

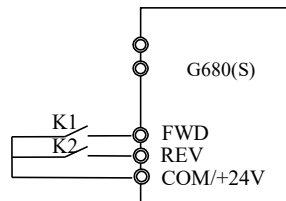

Figure3-14 Two-phase operation mode 2

**3.3.3 Three-phase operation mode 1 (F6-11=2):**The SB1 (Din) terminal serves as an enable input, with the direction being controlled by FWD (the default X1 terminal provided from the factory) and REV (the default X2 terminal provided from the factory). However, it is essential to disconnect the SB1 (Din) signal in order to complete parking effectively.

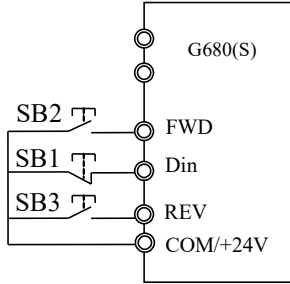

Figure3-15 Three-phase operation mode 1

Among them:

SB1(Din): Stop button (normally closed point, corresponding X terminal function set to 3: three-wire operation control)

SB2: Forward button (default X1 terminal)

SB3: Reverse button (default X2 terminal)

**3.3.4 Three-phase operation mode 2 (F6-11=3):**The enable terminal for this mode is SB1 (Din), the running command is given by FWD, and the direction is determined by the state of REV. The stop command is completed by disconnecting the signal of SB1 (Din).

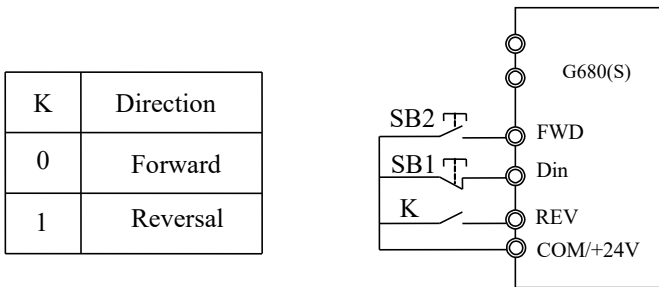

Figure 3-16. Three-phase Operation Mode 2

Among them:

SB1(Din): Stop button (normally closed point, corresponding X terminal function set to 3: three-wire operation control)

SB2: Run button (default X1 terminal)

K: Run direction button (default X2 terminal)

# Chapter 4 Operation and display

## 4.1 Introduction to the operation and display interface

With the operation panel, you can modify the functional parameters of the frequency converter, monitor the working status of the frequency converter and control the operation of the frequency converter (start, stop) and other operations, its appearance and functions are shown in the figure below. The appearance and functions of the panel are shown in the figure below

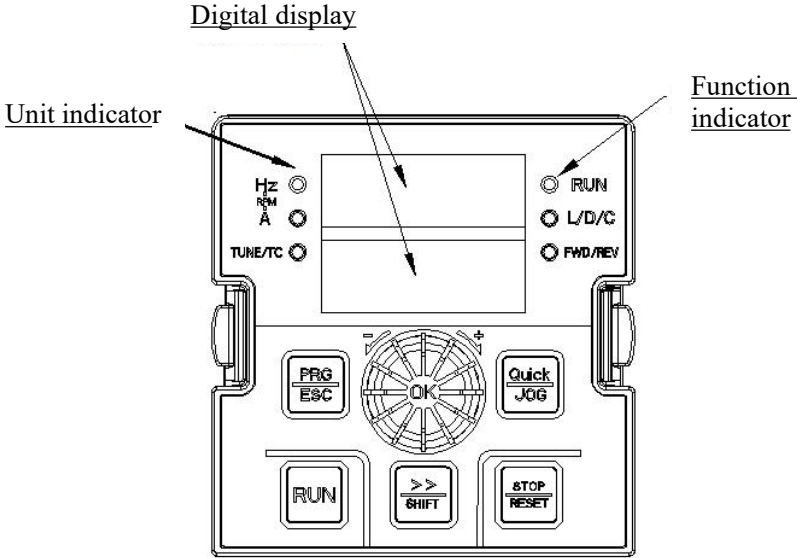

Figure 4-1. Schematic diagram of operation panel 1 (standard configuration LED keypad 1)

### 4.1.1 Indicator light description

LED Symbol		Unit	Implication	Color
Unit LED	Hz	Freq. Unit	LED on— current parameter is frequency value	Green
	A	Current Unit	LED on— current parameter is current value	Green
	RPM (Hz+A)	Speed Unit	LED on —current parameter is rotation speed value	Green
Function	% (Hz+V )	Percentage	LED on—current parameter is percentage value	Green

LED Symbol		Unit	Implication	Color
	RUN	Running status LED	LED on—in the status of running Light off—in the status of stop LED flash—in the status of sleep	Green
	L/D/C	Control mode LED	LED off—in the status of keyboard control mode LED on—in the status of terminal control mode LED flash—in the status of remote communication control mode	Red
	TUNE/TC	Tuning/torque control/fault indicators	Ryo - Torque Control Flashing - Tuning in progress \ Faulty state	Red

### 4.1.2 Digital display area

5-digit LED display, can display the set frequency, output frequency, various monitoring data and alarm code. Function code is usually a decimal number display, such as F0-11 function code value is displayed as "50.00", indicating the decimal number "50.00". When the function code value is displayed in hexadecimal, the highest bit of the digital tube displays "H." indicating that the current function code value is displayed in hexadecimal mode, such as F7-29 function code value is displayed as "H.003F", at this time the value of the F7-29 is The value of F7-29 is "0x3f" in hexadecimal.

The user is free to set the monitoring data for stop and run status according to function code F7-29/F7-31, see function code F7-29/F7-31 for details.

### 4.1.3 Description of keyboard buttons

Table 4-1 Keypad Menu

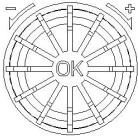
Keystrokes	Name	Function
PRG	Programming Key/Exit	One level menu to enter or exit, return to higher level menu
	Confirmation key (ENTER)	Step-by-step access to the menu screen and confirmation of setting parameters
	Incremental key (+)	Data or function code increment
	Decrement key (-)	Decrement of data or function codes

	shift key	Under the shutdown display interface and operation display interface, the display parameters can be selected cyclically, see F7-29, F7-30, F7-31 for the specific display meanings; when modifying the parameters, the modification bit of the parameters can be selected.
RUN	run key (on a computer keyboard)	For running operations in keyboard mode
STOP/RESET	Stop/Reset	During the running state, pressing this key can be used to stop the running operation; during the fault alarm state, it can be used to reset the operation, the characteristics of this key are governed by the function code F7-27.
MF.K	Tap the Run button / arrow keys	F7-28 is set to 0 for the point operation button, F7-28 is set to 1 for the direction button, press this button to reverse the direction.

## 4.2 Organization of Inverter Function Codes

The meaning of each function code group of the G680/G680S inverter is shown in the table below:

Function code group	Functional Description	Explanation
<b>F0 to FF</b>	Basic Function Parameter Set	Refer to the function code planning of mainstream inverter manufacturers
<b>C0 to C3</b>	2 <sup>nd</sup> motor parameter group	2 <sup>nd</sup> motor parameter, acceleration and deceleration time, control method, all can be set independently.
<b>E0 to E6</b>	Enhancements parameter set	System parameter setting, user function code customization, optimized control, AI/AO correction, master-slave control, holding brake function and sleep function;
<b>n0 to nF</b>	The Specialized Functional Options Group	Choose to use different specialized inverter functions.
<b>U0 to U1</b>	Monitoring parameter sets	U0 is the fault record parameter group, and U1 is the user monitoring parameter, which is convenient for checking the relevant output status; U0 is the fault record parameter group, and U1 is the user monitoring parameter.

## 4.3 Function Code Viewing and Modification Methods Description

G680/G680S inverter function code parameters adopt three-level menu structure, which can be viewed and modified through the operation panel. The three-level menu are as follows:

Function parameter group (I-level menu)→ Function code (II-level menu)→ Function code set value (III-level menu). The operation flow is shown in Figure 4-2. When in the state parameter interface, you can view different state parameters through the " " key.

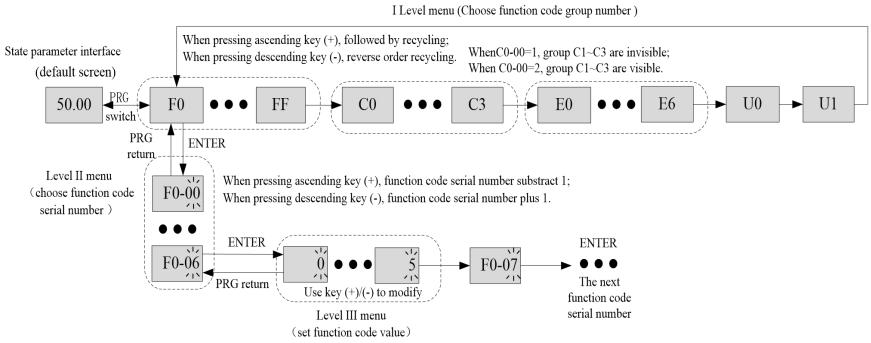

Figure 4-2. Three-level menu operation flowchart

Note: When operating in the three-level menu, you can press the **PRG** key or **ENTER** key to return to the second-level menu. However, pressing **ENTER** will save the current parameter modification value and transfer to the next function code; while pressing **PRG** will abandon the current parameter modification.

Example: Change the setting of function code F2-04 from 0.00Hz to 5.00Hz.

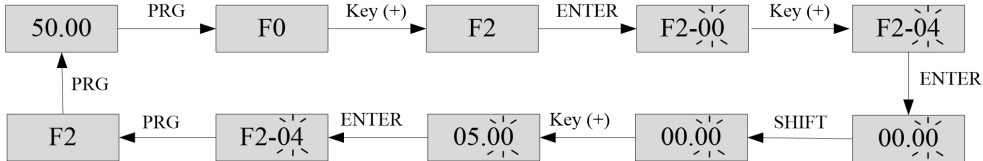

Figure 4-3. Parameter Setting Operation Flowchart

In the third level menu state, if the parameter does not have a blinking bit, it means that the parameter value of the function code cannot be modified, the specific reason can be seen in the description of the function code attributes.

## 4.4 Function Code Menu Modes and Switching Instructions

### 4.4.1 Definition and Operation of Multifunction Shortcut Keys

The function of the Quick/Jog button can be defined by the F7-28 function code.

F7-28	Quick/Jog key function selection		Default	0	
	Setting range	0	Positive rotation point movement		
		1	Forward and reverse switching		
		2	Reverse point movement		
3		Switching between panel control and remote control			

			(terminal or communication)
--	--	--	-----------------------------

Quick/Jog is a multi-function key; it can set the function by this function code. It can switch both in stop and running status.

0: Forward jog

Achieve the forward jog function by the Quick/Jog key.

1: Switch between forward and reverse

Switch the frequency command direction by the Quick/Jog key, but it's effective only the instruction source in panel command channel.

2: Reverse jog

Achieve the reverse jog function by the Quick/Jog key.

3: Switch between panel control and remote control (terminal or communication)

Switch between present instruction source and keyboard control (local operation). It's ineffective if the present instruction source is keyboard control.

### 4.4.2 Function Code Menu Mode

**Menu mode switching operation:** the first step E0-03=1 LED menu mode switching is valid, the second step press and hold the confirmation key for more than 2S for menu mode switching.

In order to facilitate the user to view and operate, G680/G680S provide three menu mode switching display of function codes.

Menu mode	Description
-BASE Basic Menu Mode	Function code parameters are displayed sequentially, F0 to FF, C0 to C3, E0 to E6, U0 to U1, of which C1 to C3 are displayed only for the second motor, and F1 to FF are displayed in relation to the F0-00 parameter setting and are not displayed by default.
-USER User-customized parameter modes	Only user-customized function parameters are displayed (up to 31 customized), which can be freely defined by E1 group. The function code starts with the letter U, and the function code parameter values can be directly modified. The inverter has already defined 19 commonly used user function codes for the user from the factory, while the user can clear the user customized function codes through E1-00 and subsequently redefine E1-01 to E1-31.
-NOTF Default value modify mode	When enter this mode, it only display the function codes which are different from the default parameter. The function codes are start with "N".

### 4.5 Multi-Segment Speed Switch Combination Instruction Description

Table 4-2 Multi-speed instruction combination function description: K1, K2, K3, and K4 shown in the table correspond to 12: Multi-speed instruction terminal 1, 13: Multi-speed instruction terminal 2, 14: Multi-speed instruction terminal 3, and 15: Multi-speed instruction terminal 4 of the function code content of the G6 group X (DI) input terminals respectively.

**Application example:** As shown in the table, the first line when K1-K4 are disconnected, the implementation of multi-speed 0 set frequency; the second line when only K1 is closed, the implementation of multi-speed 1 set frequency, and so on.

K4	K3	K2	K1	Frequency setting	Corresponding parameters
OFF	OFF	OFF	OFF	Multi-speed 0	FC-00
OFF	OFF	OFF	ON	Multi-speed 1	FC-01
OFF	OFF	ON	OFF	Multi-speed 2	FC-02
OFF	OFF	ON	ON	Multi-speed 3	FC-03
OFF	ON	OFF	OFF	Multi-speed 4	FC-04
OFF	ON	OFF	ON	Multi-speed 5	FC-05
OFF	ON	ON	OFF	Multi-speed 6	FC-06
OFF	ON	ON	ON	Multi-speed 7	FC-07
ON	OFF	OFF	OFF	Multi-speed 8	FC-08
ON	OFF	OFF	ON	Multi-speed 9	FC-09
ON	OFF	ON	OFF	Multi-speed 10	FC-10
ON	OFF	ON	ON	Multi-speed 11	FC-11
ON	ON	OFF	OFF	Multi-speed 12	FC-12
ON	ON	OFF	ON	Multi-speed 13	FC-13
ON	ON	ON	OFF	Multi-speed 14	FC-14
ON	ON	ON	ON	Multi-speed 15	FC-15

## Chapter 5 Troubleshooting and Countermeasures

### 5.1 Fault Alarms and Countermeasures

When a fault occurs during system operation, the frequency converter will immediately protect the motor and stop output, while the corresponding frequency converter fault relay contact operates. The inverter panel displays the fault code, the fault code corresponding to the type of fault and common solutions are detailed in the following table. Listed in the table is for reference only, please do not repair, transformation, if you can not troubleshooting, please seek technical support from our company or product agents.

Table 4-1 Fault Alarms and Countermeasures

Fault name	Display	Possible Causes	Solutions
Inverter module protection	Err01	<ol style="list-style-type: none"> <li>1. The motor connecting end U, V, W there is no phase to phase or short circuit to ground</li> <li>2. Whether the module is overheated</li> <li>3. Whether the inverter internal wiring is loose</li> <li>4. The main control board, driver board or module is normal</li> </ol>	<ol style="list-style-type: none"> <li>1. Contact short circuit</li> <li>2. Fan, air duct is normal</li> <li>3. Connect all loose wires</li> <li>4. Seek technical support</li> </ol>
Over-current during acceleration	Err04	<ol style="list-style-type: none"> <li>1. The inverter output circuit there is a ground or short circuit</li> <li>2. Incorrect motor parameters</li> <li>3. Acceleration time is too short</li> <li>4. V / F torque boost or curve is not appropriate</li> <li>5. Low input voltage</li> <li>6. Starting the motor that is rotating</li> <li>7. Accelerate the process of sudden load</li> <li>8. Inverter selection is small</li> </ol>	<ol style="list-style-type: none"> <li>1. Troubleshooting peripheral faults</li> <li>2. Check the parameters and parameter identification</li> <li>3. Increase acceleration time</li> <li>4. Adjust the V/F lifting torque or curve</li> <li>5. Adjust the voltage to the normal range</li> <li>6. Select speed tracking start or wait for the motor to stop and then start again</li> <li>7. Cancellation of surge loads</li> <li>8. The choice of power level greater inverter</li> </ol>

Fault name	Display	Possible Causes	Solutions
Over-current during deceleration	Err05	<ol style="list-style-type: none"> <li>1. The inverter output circuit there is a ground or short circuit</li> <li>2. Incorrect motor parameters</li> <li>3. Deceleration time is too short</li> <li>4. Low input voltage</li> <li>5. Suddenly add load during deceleration</li> <li>6. No braking unit and braking resistor</li> <li>7. Excessive flux braking gain</li> </ol>	<ol style="list-style-type: none"> <li>1. Troubleshooting peripheral faults</li> <li>2. Motor parameter identification</li> <li>3. Increase the deceleration time</li> <li>4. Adjust the voltage to the normal range</li> <li>5. Cancellation of surge loads</li> <li>6. Adding brake units and resistors</li> <li>7. Reduced flux braking gain</li> </ol>
Over-current in constant speed operation	Err06	<ol style="list-style-type: none"> <li>1. The inverter output circuit there is a ground or short circuit</li> <li>2. Incorrect motor parameters</li> <li>3. Low input voltage</li> <li>4. Whether there is a sudden load in the operation</li> <li>5. Inverter selection is small</li> </ol>	<ol style="list-style-type: none"> <li>1. Troubleshooting peripheral faults</li> <li>2. Check the parameters and parameter identification</li> <li>3. Adjust the voltage to the normal range</li> <li>4. Cancellation of surge loads</li> <li>5. The choice of power level greater frequency converter</li> </ol>
Over-voltage during acceleration	Err08	<ol style="list-style-type: none"> <li>1. Input voltage is too high</li> <li>2. The acceleration process there is an external force drag motor operation</li> <li>3. Acceleration time is too short</li> <li>4. No braking unit and braking resistor</li> <li>5. Incorrect motor parameters</li> </ol>	<ol style="list-style-type: none"> <li>1. Adjust the voltage to the normal range</li> <li>2. Cancel this power or add braking resistance</li> <li>3. Increase acceleration time</li> <li>4. Adding brake unit and resistor</li> <li>5. Checking parameters and parameter identification</li> </ol>
Over-pressure during deceleration	Err09	<ol style="list-style-type: none"> <li>1. Input voltage is too high</li> <li>2. Deceleration process there is an external force drag motor operation</li> <li>3. The deceleration time is too short</li> <li>4. No braking unit and braking resistor</li> </ol>	<ol style="list-style-type: none"> <li>1. Adjust the voltage to the normal range</li> <li>2. Cancel this power or add braking resistance</li> <li>3. Increase the deceleration time</li> <li>4. Adding brake unit and resistor</li> </ol>
Over-voltage in constant speed operation	Err10	<ol style="list-style-type: none"> <li>1. Input voltage is too high</li> <li>2. The acceleration process there is an external force drag motor operation</li> </ol>	<ol style="list-style-type: none"> <li>1. Adjust the voltage to the normal range</li> <li>2. Cancel this power or add braking resistance</li> </ol>
Under-voltage fault	Err12	<ol style="list-style-type: none"> <li>1. Instantaneous power failure</li> <li>2. Inverter input voltage is not in the range of specification</li> </ol>	<ol style="list-style-type: none"> <li>1. Reset fault</li> <li>2. Adjust the voltage to the normal range</li> </ol>

Fault name	Display	Possible Causes	Solutions
		requirements 3. Bus voltage is not normal 4. Rectifier bridge and buffer resistance is not normal 5. Driver board abnormality 6. Control board abnormality	3. Seeking technical support
Drive overload faults	Err13	1. Whether the load is too large or occurs motor blocking 2. Inverter selection is small	1. Reduce the load and check the motor and mechanical conditions 2. Select a larger power level inverter
Motor overload faults	Err14	1. Whether the motor protection parameter F9-01 is set appropriately or not 2. Whether the load is too large or the motor is blocked 3. Inverter selection is small	1. Set this parameter correctly 2. Reduce the load and check the motor and mechanical conditions 3. The choice of power level greater frequency converter
Drive overheating	Err15	1. High ambient temperature 2. Air duct blockage 3. Fan damage 4. The thermally sensitive resistor of the module is damaged. 5. Damage to the inverter module	1. Reduce the ambient temperature 2. Clean the air duct 3. Replace the fan 4. Replace the damaged thermally sensitive resistor. 5. Replacement of inverter module
Current Detection Fault	Err17	1. Inverter internal wiring whether loose 2. The current detection device is normal 3. The main control board or driver board is normal	1. Check wiring 2. Seek technical support
Short-circuit fault to ground	Err20	Motor shorted to ground	Replacement of cables or motors
Input phase failure	Err23	1. Three-phase input power is not normal 2. Driver board abnormality 3. Abnormal lightning protection board 4. Main control board abnormality	1. Check and eliminate problems in peripheral wiring 2. Seek technical support
Output phase failure	Err24	1. Inverter to motor lead is not normal 2. Motor running inverter	1. Troubleshooting peripheral faults 2. Check the motor three-phase

Fault name	Display	Possible Causes	Solutions
		three-phase output imbalance 3. Driver board abnormality 4. Module exceptions	winding is normal and troubleshooting 3. Seeking technical support
Parameter read/write failure	Err25	EEPROM chip damage	Replacement of the main control board
Malfunction of communications	Err27	1. Whether the upper computer is working 2. Communication wiring is normal 3. Communication parameters F8 group is correct	1. Check the upper computer wiring, etc. 2. Check communication wiring 3. Check the F8 group parameters
External fault	Err28	1. Through the multi-function DI (X) terminal input external normally open or normally closed fault signal	1. Fault reset
Excessive speed deviation	Err29	1. The load is too heavy and set the acceleration time is too short 2. Fault detection parameters F9-31, F9-32 set unreasonable	1. Extend the setting acceleration and deceleration time 2. Reset F9-31, F9-32
User-defined fault 1	Err30	1. User-defined fault 1 signal input via multi-function terminal DI (X)	1. Reset
User-defined fault 2	Err31	2. User-defined fault 2 signal input via multi-function terminal DI (X)	1. Reset
Loss of PID feedback at runtime	Err32	1. PID feedback value is less than FA-13 set value	1. Check the feedback signal or reset FA-13
Fast current limiting	Err33	1. Excessive load or blockage 2. Setting the acceleration time is too short	1. Reduce the load or replace the higher power inverter 2. Appropriately extend the acceleration time
Unloading fault	Err34	1. Dropped load detection conditions arrive, the specific use of reference F9-28-F9-30	1. Reset or reset detection conditions
Input power failure	Err35	1. Input voltage is not within the specified range 2. Up and down power too often	1. Adjust the input voltage 2. Extend the power up and down cycle
Parameter storage exception	Err37	Abnormal communication between DSP and EEPROM chip	1. Replace the main control board 2. Seek the services of

Fault name	Display	Possible Causes	Solutions
			manufacturers
This run time arrives	Err39	1. Inverter this running time > F7-39 set value	1. Reset
Cumulative running time reaches	Err40	1. Accumulated running time reaches set value F7-20	1. Use the parameter initialization function 2 to clear the recording time or reset the accumulated running time
Switching motors during operation	Err42	Switching of motors via terminals during operation	Motor switchover after shutdown
PID feedback overrun fault during operation	Err44	1. The PID feedback value exceeds the FA-16 setpoint; 2. For over-temperature or over-voltage protection in case of constant temperature or pressure control.	1. Check feedback signal or reset FA-16 2. PID overrun protection is invalid when FA-17 is set to 0 S
Permanent magnet synchronous motor initial position identification fault	Err45	1. Detecting abnormalities in the motor wires 2. Detection of motor abnormality 3. Current Sense Failure or Hall Failure 4. Increase initial position recognition voltage F4-28	1. Test the motor and line is normal, abnormal replacement 2. Use a multi-meter to detect whether the motor three-phase balance
Master-Slave Communication Dropout	Err46	1. No master set but slave set 2. Communication line abnormality or incorrect communication parameters	1. Set the host and reset the fault 2. Check the communication line and communication parameters F8 group
Constant pressure water supply water shortage protection	Err47	Used for constant pressure water supply pipe water shortage protection, water supply application macro to open to have this function	1. Confirm whether the water pipe is real lack of water 2. Check the PID feedback wiring, the sensor is not a problem 3. The default every 20 minutes automatically reset to ensure that the water pipe water automatically reset after the normal constant pressure water supply, F1-10 = 0 protection is not effective
Permanent magnet	Err48	1、 Motor parameter setting error 2、 Is the motor demagnetised	1.Check the electrical parameters of the motor, or ask

Fault name	Display	Possible Causes	Solutions
synchronous motor reverse potential recognition error faults		3. Is there any abnormality in the motor power cable	the motor manufacturer. 2.Detecting whether the motor is demagnetised with an instrument 3. Detect whether the motor power cord is abnormal

## 5.2 Common faults and their treatment

The following faults may be encountered during the use of the inverter, please refer to the following method for simple fault analysis.

Table 4-2 Common faults and treatment methods

Serial number	Fault phenomenon	Possible causes	Solutions
1	No display at power-on	1: There is no power supply or the power supply is too low. 2: The switching power supply on the drive board is faulty. 3: The rectifier bridge is damaged. 4: The buffer resistor of the drive is damaged. 5: The control board or the keypad is faulty. 6: The cable between the control board and the drive board or keypad breaks.	1: Check the power supply. 2: Check the bus voltage. 3: Re-connect the keypad and 30-core cables. 4: Contact the agent for technical support.
2	"Err20" is displayed at power-on.	1: The motor or the motor output cable is short-circuited to the ground. 2: The AC driver is damage.	1: Measure the insulation of the motor and the output cable with a megger. 2: Contact the agent for technical support.
3	Err15 (module overheating) faults reported	1: The setting of carrier frequency is too high. 2: The cooling fan is damaged, or the air filter is blocked. 3: Components inside the AC drive are damaged (thermal coupler or others).	1: Reduce the carrier frequency (F0-26). 2: Replace the fan and clean the air filter. 3: Contact the agent for technical support.
4	Motor does not rotate after inverter runs	1: Check the motor and the motor cables. 2: The AC drive parameters are set improperly (motor parameters).	1: Ensure the cable between the AC drive and the motor works. 2: Replace the motor or clear mechanical faults. 3: Check and re-set motor parameters.

Serial number	Fault phenomenon	Possible causes	Solutions
		3: The cable between the drive board and the control board is in poor contact. 4: The drive board is faulty.	
5	X(DI) terminal failure	1. Wrong parameter setting 2. External signal error 3.X(DI)dial switch is in the wrong position 4.Control board failure	1. Check and reset F5 group related parameters 2.Re-connect the external signal line 3. Re-confirm that the position of the X (DI) dip switch is the same as the wiring method. 4. Contact the agent for technical support.
6	Frequent over-current and over-voltage faults	1.Motor parameters are not set correctly 2.Inappropriate acceleration and deceleration time 3.Load fluctuation	1.Reset motor parameters or motor tuning 2.Set the appropriate acceleration and deceleration time 3. Contact the agent for technical support.

# Chapter 6 G680/G680S Modbus Communication Protocol

G680/G680S series inverter provides RS232/RS485 communication interface and supports Modbus communication protocol. Users can realize centralized control through computer or PLC, set inverter operation commands, modify or read function code parameters, read inverter working status and fault information through this communication protocol.

## 1. Content of the agreement

This serial communication protocol defines the content of the information transmitted in serial communication and the format used. These include: the host polling (or broadcasting) format; the coding method of the host, which includes: the function code of the requested action, the transmitted data and the error check, and so on. The slave's response adopts the same structure, including: action confirmation, return data and error checking. If the slave makes an error in receiving information or fails to complete the action requested by the host, it will organize a fault message as a response back to the host.

## 2. Application methods

The inverter is connected to a PC/PLC control network with RS232/RS485 buses.

## 3. Bus structure

### (1) Interface

RS232/RS485 hardware interface

### (2) Transmission method

Asynchronous serial, half-duplex transmission. At the same time only one of the host and the slave can send data and the other can only receive data. Data is sent in the form of telegrams, frame by frame, during serial asynchronous communication.

### (3) Topology

Single master multi-slave system. Slave addresses are set in the range of 1 ~ 247, with 0 being the broadcast communication address. Slave addresses must be unique in the network.

## 4. Description of the agreement

The communication protocol of G680/G680S series inverter is an asynchronous serial master-slave Modbus communication protocol, only one device (host) in the network can establish the protocol (called "query/command"), other devices (slaves) can only respond to the host's "query/command" by providing data or make corresponding actions according to the host's "query/command". The other devices (slaves) can only respond to the host's

"query/command" by providing data, or make corresponding actions according to the host's "query/command". The master here refers to a personal computer (PC), industrial control device or programmable logic controller (PLC), etc., and the slave refers to the G680/G680S inverter. The master can communicate with a slave individually or broadcast messages to all subordinate slaves. For individually accessed host "queries/commands", the slaves all return a message (called a response), and for broadcast messages issued by the host, the slaves do not need to return a response to the host.

**5. Communication frame structure**

The Modbus protocol communication data format of G680/G680S series inverter is as follows.

Using RTU mode, message sending must begin with a pause interval of at least 3.5 character times. With varied character times at network baud rates, this is the easiest to achieve (as shown in T1-T2-T3-T4 in the figure below). The first field transmitted is the device address. The transmission characters that can be used are the hexadecimal 0...9,A...F. F. The network device continuously detects the network bus, including during the pause interval. When the first field (address field) is received, each device decodes it to determine if it is addressed to itself. After the last transmitted character, a pause of at least 3.5 character time marks the end of the message. A new message may begin after this pause.

The entire message frame must be transmitted as a continuous stream. If there is a pause of more than 1.5 characters before the frame is complete, the receiving device refreshes the incomplete message and assumes that the next byte is the address field of a new message. Similarly, if a new message follows the start of the previous message in less than 3.5 character time, the receiving device will assume that it is a continuation of the previous message. This will result in an error because the value in the last CRC field cannot be correct.

RTU frame format:

Frame header START	3.5 character time
Slave address FdR	Correspondence: 1 ~ 247 (set by F8-02)
Command Code D	03: Read slave parameters; 06: Write slave parameters
Data content DATA	Information content: Function code parameter address, number of function code parameters, function code parameter value, etc.
Data content DATA	
.....	
Data content DATF0	
CRC CHK Low	Detection value: CRC16 checksum value. Transmitted with the low byte first and the high byte second. See the description of the CRC checksum in this section for details of the calculation.
CRC CHK high	
END	3.5 character time

### Command instruction (D) and data description (DATA)

Command code: 03H, read N words (Word), up to 12 words and N=1 ~ 12; 06H, write a word (Word) The specific format is as follows.

#### Host Read Command Frame

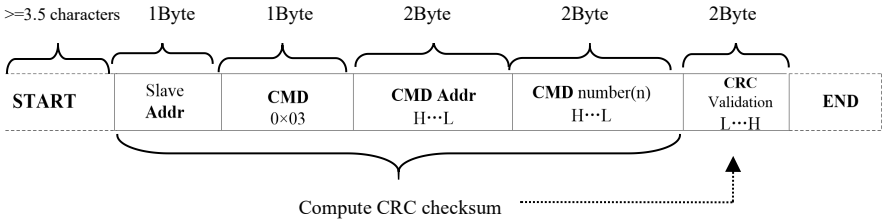

#### Slave reads an answer frame

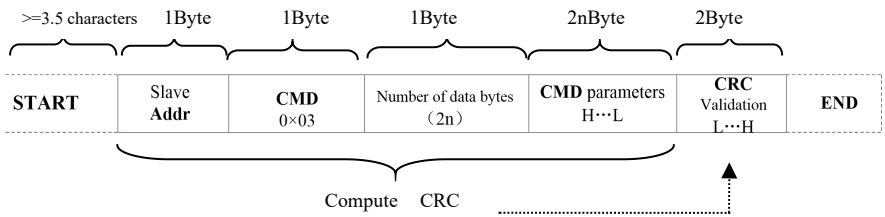

#### Host Write Command Frame

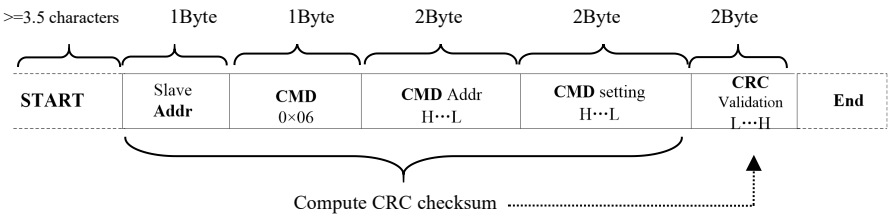

#### Slave Write Answer Frame

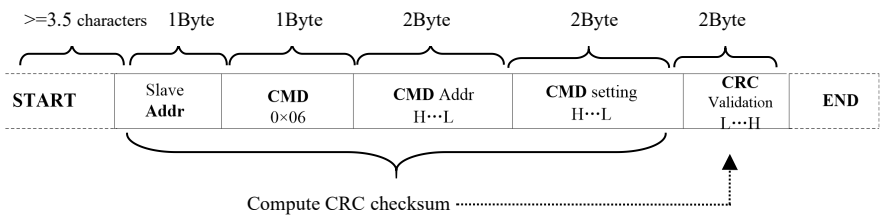

If the slave detects an error in the communication frame, or if the read or write is unsuccessful for any other reason, it will reply with an error frame. The slave read replies to the error frame:

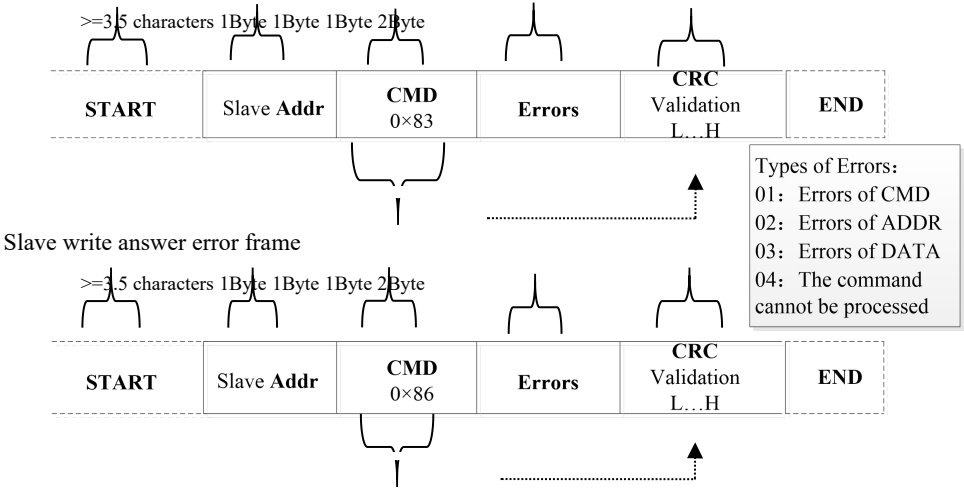

Example: Read the contents of 2 consecutive parameters starting from inverter F0-03 with slave address F8-02 as 01.

The host sends the frame as shown:

START >=3.5 characters	Slave Addr 0x01	CMD 0x03	CMD Addr 0xF0 0x03	Number of data bytes 0x00 0x02	CRC Validation 0x07 0x0B	END
------------------------------	--------------------	-------------	-----------------------	-----------------------------------	--------------------------------	-----

The slave reply frame is shown:

START >=3.5 characters	Slave Addr 0x01	CMD 0x03	Number of data bytes 0x04	A0_03 Parameters 0x00 0x00	A0_04 Parameters 0x00 0x00	CRC Validation 0xFA 0x33	END
------------------------------	--------------------	-------------	---------------------------------	----------------------------------	----------------------------------	--------------------------------	-----

**Note:** If the write command is unsuccessful it will reply with the reason for the failure.

### 6. Checksum method (CRC checksum method)

CRC (Cyclical Redundancy Check) Using the RTU frame format, the message includes an error detection field based on the CRC method. The CRC field detects the entire message. The CRC field is two bytes containing a 16-bit binary value. It is calculated by the transmitting device and added to the message. The receiving device recalculates the CRC of the received message and compares it with the value in the received CRC field. If the two CRC values are not equal, there is an error in transmission.

The CRC is first deposited into 0xFFFF, and then a procedure is called to process the consecutive 8-bit bytes in the message against the value in the current register. Only the 8-bit data in each character is valid for the CRC; the start and stop bits and the parity bit are invalid.

During CRC generation, each 8-bit character is individually differentiated (XORed) with the register contents and the result is shifted in the direction of the least significant bit and the highest significant bit is filled with 0. The LSB is extracted and detected, and the register is individually differentiated with the pre-set value if the LSB is 1, or not performed if the LSB is

0. The whole process is repeated 8 times. After the last bit (8th bit) is done, the next 8-bit byte is again individually differentiated with the current value of the register. The final value in the register is the CRC value after all the bytes in the message have been executed.

When CRC is added to a message, the low byte is added first, then the high byte. The CRC simple function is as follows:

```
unsigned int crc_chk_value(unsigned char *data_value,unsigned char length){
    unsigned int crc_value=0xFFFF;
    int I;
    while (length-->0) {
        crc_value^=*data_value++;
        for (i=0;i<8;i++) {
            if (crc_value&0x0001) {
                crc_value=(crc_value>>1)^0xF001;
            }
            else {
                crc_value=crc_value>>1;
            }
        }
    }
    return (crc_value).
}
```

## 7. Address definition of communication parameters

This part is the content of the communication, used to control the operation of the inverter, inverter status and related parameter settings.

Read/write function code parameters (some function codes cannot be changed and are for factory use or monitoring only).

Function code parameter address labeling rules.

Parameter address representation rules by function code group number and labeling.

Higher bytes: F0~FF (Group A), C0~CF (Group C), E0~EF (Group E), F0~FF (Group F), P0~PF (Group P), 70~7F (Group U) low byte:00~FF

e.g.: F0-11, address is F00B.

Caution.

Group FF: parameters can neither be read nor changed.

Group U: Read only, no parameter changes.

Some parameters can not be changed when the frequency converter is in operation; some

parameters can not be changed regardless of what state the frequency converter is in; change the function code parameters, but also pay attention to the scope of the parameters, units, and related instructions.

Group number of function code	Access address of communication	Function code address of communication revise the RAM
Groups F0 to FE	0xF000 to 0xFFFF	0x0000 to 0x0EFF
Groups C0 to CF	0xB000 to 0xBFFF	0x4000 to 0x4FFF
Groups E0 to EF	0xC000 to 0xCFFF	0x5000 to 0x5FFF
Groups n0 to n1	0xD000 to 0xD10E	0x6000 to 0x610E
Groups U0, U1	0x70xx, 0x71xx	

Note In addition, since the life of the EEPROM will be reduced if it is stored frequently, some function codes can be used in the communication mode without storing them by simply changing the value in the RAM.

If it is a group A parameter, to realize the function, just turn the high A of the function code address to 0.

If it is a group C parameter, to realize the function, it is sufficient to change the high bit B of the address of the function code to 4.

The corresponding function code address is indicated below:

High byte: 00~ 0F (Group A), 40~ 4F (Group C) Low byte: 00~ FF

As:

Function codes F0-11 are not stored in the EEPROM and are indicated by the address 000B;

This address indicates that you can only do write RAM, not read action, and when reading, it is an invalid address.

**Shutdown/Operation Parameters section:**

Address	Parameter description	Address	Parameter description
0x1000/ 0x9000	1000:*Communication set value (-10000~ 10000) (decimal) (unit: 0.01%), readable and writable	0x1014	A11 Voltage before calibration (unit: 0.001V) read-only (computing)
	9000:Communication Setting Frequency: 0HZ~ F0-14 (Minimum Unit: 0.01HZ), Read/Write	0x1015	A12 Voltage before correction (unit: 0.001V) read-only (computing)
0x1001	Setting frequency (unit: 0.01Hz), read-only	0x1016	Actual line speed (unit: 1m/min), read-only
0x1002	Operating frequency (unit: 0.01Hz), read-only	0x1017	Load speed (unit: custom, refer to F7-32 use), read only
0x1003	Bus voltage (unit: 0.1V), read-only	0x1018	Current power-up time (unit: 1min), read-only

Address	Parameter description	Address	Parameter description
0x1004	Output voltage (unit: 0.1V), read-only	0x1019	Current running time (unit: 0.1min) read-only
0x1005	Output current (unit: 0.01A: power <=30.0kW,0.1A: power >30.0kW), read-only	0x101A	Input pulse frequency (unit: 1Hz), read-only
0x1006	Output power (unit: 0.1kW), read-only	0x101B	Main frequency X display (unit: 0.01Hz), read-only
0x1007	DI (X) input flag (unit: 1) , read-only	0x101C	Auxiliary frequency Y display (unit: 0.01Hz), read-only
0x1008	DO output flag (unit: 1), read-only	0x101D	Target torque (in 0.1%). With 100% of the rated motor torque, read-only
0x1009	PID setting (unit: 1), read-only	0x101E	Output torque (unit: 0.1%). With 100% of the rated motor torque, read-only
0x100A	PID feedback (unit: 1), read-only	0x101F	Output torque (unit: 0.1%). With the rated current of the inverter as 100%, read-only
0x100B	AI1 voltage (unit: 0.01V), read-only	0x1020	Upper torque limit (unit: 0.1%. With the rated current of the inverter as 100%, read-only
0x100C	AI2 voltage (unit: 0.01V), read-only	0x1021	VF separation target voltage (in 1V), read-only
0x100D	AO1 output voltage (unit: 0.01V) read only	0x1022	VF Separation Output Voltage (Unit: 1V), Read Only
0x100E	PLC step (unit: 1), read-only	0x1023	Reserved, read-only
0x100F	Rotation speed (unit: 1rpm), read-only	0x1024	Motor 1\2 indication (unit: 1), read only
0x1010	Count value input (unit: 1), read-only	0x1025	Length value input (unit: 1) Read only
0x1011	Input pulse frequency (unit: 0.01kHz), read-only	0x1026	AO2 output voltage (unit: 0.01V), read-only
0x1012	Feedback rate (in 0.1Hz), read-only	0x1027	Inverter status (unit: 1), read-only
0x1013	Remaining running time (unit: 0.1min), read-only	0x1028	Current fault (unit: 1), read-only

Example 1: Read the operating frequency of the first device: 0x01 0x03 0x10 0x02 0x00 0x01 0x21 0x0A

0x10 0x02 (1002) operating frequency address, 0x00 0x01 (0001) a data  
0x21 0x0A (210A) CRC checksum value

Example 2: Read the bus voltage, output voltage and output current of the first device at the same time: 0x01 0x03 0x10 0x03 0x00 0x03 CRC check value, the data meaning is similar to example 1.

**Note:** The communication setpoint is a percentage of the relative value, 10000 corresponds to 100.00% and -10000 corresponds to -100.00%.

For frequency-range data, the percentage is the percentage relative to the maximum frequency

(F0-14); for torque-range data, the percentage is F4-21, F4-23, C3-21, C3-23.

Note: The D0 output terminal requires the 16 (communication control) function to be selected.

The AO output requires the 7 (communication control output) function to be selected.

Typology	Command address	Order content
Control Command Input (Address: 06 only)	0x2000	0001: Forward running 0002: Reverse running 0003: Forward pointing 0004: Reverse rotation spotting 0005: Free stop 0006: Deceleration stop 0007: Fault reset
status reading (read-only)	0x3000	0001: Forward operation 0002: Reverse operation 0003: Shutdown
Digital output terminal control (write-only)	0x2001	BIT0(0001): RELAY1 output control BIT1(0002): RELAY2 output control BIT3(0008): DO1 (Y1) output control
Analogue output AO1 control (write only)	0x2002	0~ 7FFF indicates 0% to 100%
Analogue output AO2 control (write only)	0x2003	0~ 7FFF indicates 0% to 100%
Inverter fault address	0x8000	0000: No fault 0001: Reserved 0002: Reservations 0003: Reservations 0004: Acceleration over-current 0005: Deceleration over-current 0006: Constant speed over-current 0007: Stop over-current 0008: Acceleration over-voltage 0009: Deceleration over-voltage 000A: Constant speed over-voltage 000B: Stop over-voltage 000C: Under-voltage fault 000D: Overload of inverter 000E: Motor overload 000F: Module overheat 0010: Reserved 0011: Current Detection Failure 0012: Reservations 0013: Reservations 0014: Motor short to ground fault 0015: Motor tuning fault 0016: Reserved 0017: Input out of phase 0018: Output out of phase 0019: EEPROM read/write abnormality 001A: Password entered more than times

Typology	Command address	Order content
		001B: Communication abnormality 001C: External fault 001D: Excessive speed deviation 001E: User-defined fault 1 001F: User-defined fault 2 0020: Loss of PID feedback at runtime 0021: Hardware current limit failure 0022: Load Drop 0023: Buffer Resistor Overload Failure 0024: Contactor abnormality 0025: Agent run time reached 0026: Motor over-temperature (reserved) 0027: Current runtime reached 0028: Cumulative runtime reached 0029: Power-up time reached 002A: Switching motor fault during operation 002B: Motor over-speed 002C: Run-time PID feedback overrun 002D: Reserved 002E: Reserved 002F: Point-to-Point Slave Failure

**Return address in case of communication failure: Read failure 83XX,Write failure 86XX**

## Chapter 7. Functional Parameters Table

The function code symbols are described as follows.

"☆ ": indicates that the inverter parameters can be modified during shutdown and operation (0)

"★ ": indicates that the inverter is in running state not modifiable (1)

"○ ": indicates that the parameter is a manufacturer's parameter and cannot be changed by the user (3)

"● ":Indicates the actual detected value of the inverter or the manufacturer's cured value, which cannot be changed (2)

The communication addresses in the functional parameter table are written in hexadecimal.

**Enhanced Function Code:** group C0 to group C3, group E0 to group E6, enabled by function parameter F7-76.

Function code	Parameter Name	Element	Default	Property	Address
<b>Group F0 - Basic Function Group</b>					
F0-00	Product Model	Model:5-digit display, 2-digit decimal point	50#. ##	●	F000
F0-01	Inverter GP type display	0: Type G 1: Type P	0	★	F001
F0-02	Rated current	0.1A~3000.0A	Determination of model	●	F002

Function code	Parameter Name	Element	Default	Property	Address
F0-03	Control method	01: Asynchronous motor open-loop vector control 02: VF Control <b>03: Closed-loop vector control of asynchronous motors</b> 11: Permanent magnet synchronous motor open loop vectors <b>13: Closed-loop vector control of permanent magnet synchronous motors</b>	02	★	F003
F0-04	Run command source	0: Operator panel run command channel (LED off) 1: Terminal command channel (LED on) 2: Communication command channel (LED blinking)	0	★	F004
F0-05	Runtime Up/Down Modify Frequency Instruction Benchmarks	0: Operating frequency 1: Setting frequency	1	★	F005

Function code	Parameter Name	Element	Default	Property	Address
F0-06	Main frequency source X selection	0: Up/Down modifies frequency shutdown without memory 1: Up/Down modification frequency power-down memory 2:AI1 3:AI2 4:Multi-Segment Speed 5:Simple PLC 6:PID 7:Communication given 8: PULSE pulse setting 9: Up/Down modification frequency shutdown memory power-down not memory	1	★	F006

Function code	Parameter Name	Element	Default	Property	Address
F0-07	Auxiliary frequency source Y selection	0: Up/Down modifies frequency shutdown without memory 1: Up/Down modification frequency power-down memory 2:A11 3:A12 4:Multi-Segment Speed 5:Simple PLC 6:PID 7:Communication given 8: PULSE pulse setting 9: Up/Down modification frequency shutdown memory power-down not memory	0	★	F007
F0-08	Auxiliary frequency source Y range selection	0:Relative to maximum frequency 1:Relative to frequency source X	0	☆	F008
F0-09	Auxiliary frequency source Y range	0% to 100%	100%	☆	F009

Function code	Parameter Name	Element	Default	Property	Address
F0-10	Frequency selection	source	00	☆	F00A
F0-11	Preset Frequency	0.00Hz ~ Maximum frequency F0-14	50.00 Hz	☆	F00B

Function code	Parameter Name	Element	Default	Property	Address
F0-13	Motor running direction selection	0: Same direction as current motor 1: Opposite to current motor direction 2: Prohibition of inversion	0	☆	F00D
F0-14	Maximum Output Frequency	When F0-20=1, the adjustable range is 50.0Hz to 1200.0Hz; When F0-20=2, the adjustable range is 50.00Hz to 600.00Hz;	50.00 Hz	★	F00E
F0-15	Upper Frequency Source	0: Digital given (F0-16) 1: AI1 2: AI2 3: Communication given 4: PULSE setting	0	★	F00F
F0-16	Upper frequency	Lower limit frequency F0-18 ~ Maximum frequency F0-14	50.00 Hz	☆	F010
F0-17	Upper Frequency Bias	0.00 to maximum frequency F0-14	0.00Hz	☆	F011
F0-18	lower frequency	0.00Hz to upper limit frequency F0-16	0.00Hz	☆	F012

Function code	Parameter Name	Element	Default	Property	Address
F0-19	Command Source Binding Selection	Digit: Operation panel command binding frequency source selection 0: No binding 1: Digital set frequency 2: AI1 3: AI2 4: Multi-segment speed 5: Simple PLC 6: PID 7: Communication given 8: PULSE pulse setting (DI7 (X7)) Ten positions: terminal command binding frequency source selection Hundred bits: communication command binding frequency source selection Thousandths digit: reserved	000	☆	F013
F0-20	Frequency Decimal Selection	1: 1 decimal place 2: 2 decimal places	2	★	F014
F0-21	Acceleration and deceleration time units	0: 1 second 1: 0.1 second 2: 0.01 second	1	★	F015

Function code	Parameter Name	Element	Default	Property	Address
F0-22	Acceleration and deceleration time reference frequency	0: Maximum frequency (F0-14) 1: Preset frequency (F0-11) 2: Motor rated frequency (F1-05 or C1-05)	0	★	F016
F0-23	Acceleration time 1	0s to 30000s (F0-21=0) 0.0s to 3000.0s (F0-21=1) 0.00s to 300.00s (F0-21=2)	10.0s	☆	F017
F0-24	Deceleration time 1	0s to 30000s (F0-21=0) 0.0s to 3000.0s (F0-21=1) 0.00s to 300.00s (F0-21=2)	10.0s	☆	F018
F0-25	Over-modulated voltage boost value	0% to 10%	3 %	★	F019
F0-26	carrier frequency	0.5kHz~16.0kHz	Determination of model	☆	F01A
F0-27	Carrier Frequency Adjustment with Temperature	0: not valid; 1: valid;	1	☆	F01B

Function code	Parameter Name	Element	Default	Property	Address
F0-28	Parameter initialization	0: No operation 1: Restore factory parameters, excluding motor parameters, record information and frequency decimal point F0-20 2: Clearing of recorded information 3: Backup user's current parameters 4: Restore user backup parameters	0	★	F01C
F0-29	LCD upload and download parameter selection	0: No function 1: Download parameters to LCD 2: Upload only F1 group parameters 3: Uploading parameters other than group F1 4: Upload all parameters	0	☆	F01D
<b>Group F1 - first motor parameters</b>					
F1-00	Motor parameter tuning	0: No function 1: Static tuning 2: Rotary tuning		★	F100
F1-01	Motor 1 rated power	0.1kw~1000.0kw	Determination of model	★	F101
F1-02	Motor 1 rated voltage	0V to 1500V		★	F102

Function code	Parameter Name	Element	Default	Property	Address
F1-03	Motor 1 Number of motor poles	2 to 64	Determination of model	○	F103
F1-04	Motor 1 rated current	0.01A ~ 600.00A (motor rated power ≤30.0kW) 0.1A ~ 6000.0A (motor rated power >30.0kW)	F1-01 Determination	★	F104
F1-05	Motor 1 rated frequency	0.00Hz to F0-14	50.00 Hz	★	F105
F1-06	Motor 1 rated speed	0rpm~60000rpm	F1-01 Determination	★	F106
F1-07	Motor 1 no-load current	0.01A to F1-04 (Motor rated power ≤30.0kW) 0.1A to F1-04 (motor rated power >30.0kW)	Determination of model	★	F107
F1-08	Asynchronous motor 1 stator resistance	0.001Ω~65.535Ω	Determination of model	★	F108
F1-09	Asynchronous motor 1 rotor resistance	0.001Ω~65.535Ω	Determination of model	★	F109
F1-10	Asynchronous motor 1 mutual inductance	0.1 Mh to 6553.5 Mh	Determination of model	★	F10A
F1-11	Asynchronous motor 1 leakage inductance	0.01Mh to 655.35Mh	Determination of model	★	F10B
F1-12	Acceleration during dynamic full tuning	1.0s to 6000.0s	10.0s	☆	F10C
F1-13	Deceleration during dynamic full tuning	1.0s to 6000.0s	10.0s	☆	F10D

Function code	Parameter Name	Element	Default	Property	Address
F1-17	Synchronous motor stator resistance	0.001Ω~65.535Ω	Determination of model	★	F111
F1-18	Synchronous motor D-axis inductance	0.01Mh to 655.35Mh	Determination of model	★	F112
F1-19	Synchronous motor Q-axis inductance	0.01Mh to 655.35Mh	Determination of model	★	F113
F1-20	Synchronous motor reaction potential	1V to 65535V	Determination of model	★	F114
F1-28	Number of encoder pulse lines	1 to 65535	1024	★	F11C
F1-29	Encoder Type	0: ABZ incremental encoder 2: Rotary Transformer	0	★	F11D
F1-31	Encoder AB phase sequence	0: Positive 1: Reversed	0	★	F11E
F1-32	Encoder mounting angle	0 to 3599	0	★	F11F
F1-35	Logarithm of the spin pole (math)	1 to 65535	1	★	F123
F1-37	Speed Feedback PG Break Detection Time	0.0s to 10.0s	0.0s	★	F125
<b>Group F2 - Start-Stop Control</b>					

Function code	Parameter Name	Element	Default	Property	Address
F2-00	Activation method	0:Direct start 1:Speed tracking 2:Asynchronous motor pre-excitation starting	0	☆	F200
F2-01	RPM tracking method	0:Start from stop frequency 1:Start from target frequency 2:Starting from the maximum frequency	0	★	F201
F2-02	Speed tracking current max.	30% to 150%	100%	★	F202
F2-03	RPM tracking fast or slow	1 to 100	20	☆	F203
F2-04	Start-up frequency	0.00Hz to 10.00Hz	0.00Hz	☆	F204
F2-05	Start-up frequency hold time	0.0s to 100.0s	0.0s	★	F205
F2-06	Starting DC braking current	0% to 100%	0%	★	F206
F2-07	Start DC braking time	0.0s to 100.0s	0.0s	★	F207
F2-08	Acceleration/deceleration frequency curve mode selection	0: Straight line 1: S-curve A 2: S-curve B (F2-09 to F2-12 in 0.01s)	0	★	F208
F2-09	S-curve acceleration start time	0.0% to 100.0%	20.0%	★	F209

Function code	Parameter Name	Element	Default	Property	Address
F2-10	S-curve acceleration end time	0.0% to 100.0%	20.0%	★	F20A
F2-11	S-curve deceleration start time	0.0% to 100.0%	20.0%	★	F20B
F2-12	S-curve deceleration end time	0.0% to 100.0%	20.0%	★	F20C
F2-13	Shutdown mode	0: Deceleration stop 1: Free stop	0	☆	F20D
F2-14	Stopping DC braking start frequency	0.00Hz to F0-14	0.00Hz	☆	F20E
F2-15	Shutdown DC braking wait time	0.0s to 100.0s	0.0s	☆	F20F
F2-16	Shutdown brake DC current	0% to 100%	0%	☆	F210
F2-17	Stopping DC braking time	0.0s to 36.0s	0.0s	☆	F211
F2-21	demagnetisation time	0.01s ~3.00s	0.50s	★	F215
F2-22	Downtime delay	0.00s to 1.00s	0.20s	☆	F216
F2-23	Instant stop non-stop option	0: Invalid 1: Automatic adjustment of deceleration rate 2: Deceleration stop	0	★	F217
F2-24	Deceleration time for instantaneous non-stop deceleration stops	0.0s to 100.0s	10.0s	★	F218

Function code	Parameter Name	Element	Default	Property	Address
F2-25	Voltages in effect without stopping or stopping	60 to 85%	80%	★	F219
F2-26	Instantaneous non-stop recovery voltage	85-100%	90%	★	F21A
F2-27	Instantaneous non-stop recovery voltage judgement	0.0s to 300.0s	0.3s	★	F21B
F2-28	Automatic gain adjustment without stopping	0 to 100	40	☆	F21C
F2-29	Automatic adjustment of points without stopping	1 to 100	20	☆	F21D
<b>Group F3 - V/F control parameters</b>					
F3-00	V/F curve setting	0: Straight VF curve 1: Multi-point VF curve 2: Square VF curve 3: 1.7 power curve 4: 1.5 power curve 5: 1.3 power curve 6: VF fully separated mode 7: V/F semi separated mode	0	★	F300
F3-01	Torque Increase	0.0% to 30.0%	0.0%	☆	F301
F3-02	Torque boost cut-off frequency	0.00Hz to maximum frequency	45.00 Hz	★	F302
F3-03	V/F frequency point F1	0.00Hz~ F3-05	1.30 Hz	★	F303

Function code	Parameter Name	Element	Default	Property	Address
F3-04	V/F voltage point V1	0.0% to 100.0%	5.2%	★	F304
F3-05	V/F frequency point F2	F3-03 to F3-07	2.50Hz	★	F305
F3-06	V/F voltage point V2	0.0% to 100.0%	8.8%	★	F306
F3-07	V/F frequency point F3	0.00 Hz to 50.00 Hz	15.00 Hz	★	F307
F3-08	V/F voltage point V3	0.0% to 100.0%	35.0%	★	F308
F3-09	Differential Compensation Factor	0.0% to 200.0%	0.0%	☆	F309
F3-10	Flux Braking Gain	0 to 200	100	☆	F30A
F3-11	Oscillation suppression gain	0 to 100	Determination of model	☆	F30B
F3-13	VF Differential Compensation Time Constant	0.02s to 1.00s	0.30s	☆	F30D
F3-15	Output Voltage Source Selection for VF Separation	0: Digital setting (F3-14) 1: AI1 2: AI2 3: Multi-segment instruction 4: Simple PLC 5: PID 6: Communication given 7: PULSE pulse setting (DI7 (X7)) 100.0% corresponds to rated motor voltage	0	☆	F30F

Function code	Parameter Name	Element	Default	Property	Address
F3-16	V/F split output voltage digital setting	0V~Motor rated voltage	0V	☆	F310
F3-17	V/F separation output voltage acceleration time	0.0 to 3000.0s	1.0s	☆	F311
F3-18	V/F split output voltage deceleration time	0.0 to 3000.0s	1.0s	☆	F312
F3-19	V/F Separation stop mode selection	0: Frequency and output voltage deceleration time independent 1: Frequency decreases after voltage decreases to 0	0	☆	F313
F3-20	V/F torque boost gain	0.0% to 300.0%	50%	☆	F314
<b>Group F4 - Vector control parameters</b>					
F4-00	Switching frequency F1	1.00 to F4-02	5.00 Hz	☆	F400
F4-02	Switching frequency F2	F4-00 to F0-14	10.00 Hz	☆	F402
F4-04	Low frequency speed proportional gain	0.1 to 10.0	4.0	☆	F404
F4-05	Low Frequency Velocity Integration Time	0.01s~10.00s	0.50s	☆	F405
F4-06	High frequency speed proportional gain	0.1 to 10.0	2.0	☆	F406
F4-07	High Frequency Velocity Integration Time	0.01 to 10.00s	1.00s	☆	F407
F4-08	Speed Ring Points Attribute Selection	0: Points in effect 1: Points separated	0	★	F408

Function code	Parameter Name	Element	Default	Property	Address
F4-11	Torque current regulator Kp	0 to 30000	2200	☆	F40B
F4-12	Torque current regulator Ki	0 to 30000	1500	☆	F40C
F4-13	Excitation current regulator Kp	0 to 30000	2200	☆	F40D
F4-14	Excitation current regulator Ki	0 to 30000	1500	☆	F40E
F4-15	Flux Braking Gain	0 to 200	0	☆	F40F
F4-16	Weak magnetic torque correction factor	50% to 200%	100%	☆	F410
F4-17	Differential Compensation Gain	50% to 200%	100%	☆	F411
F4-18	Velocity loop feedback filter time constant	0.000 to 1.000s	0.015s	☆	F412
F4-19	Velocity loop output filter time constant	0.000 to 1.000s	0.000s	☆	F413
F4-20	Electric Torque Limit Source	0: F4-21 1: AI1 2: AI2 3: Communication given 4: PLUSE given (Analogue range corresponds to F4-21)	0	☆	F414
F4-21	Upper limit of electric torque	0.0% to 200.0%	150.0%	☆	F415

Function code	Parameter Name	Element	Default	Property	Address
F4-22	Braking torque upper limit source	0: F4-23 1: AI1 2: AI2 3: Communication given 4: PLUSE given (Analogue range corresponds to F4-23)	0	☆	F416
F4-23	Upper limit of braking torque	0.0 to 200.0%	150.0%	☆	F417
F4-24	Synchronous motor low speed magnetizing current	0.0% to 50.0%	25.0%	★	F418
F4-25	Synchronous motor magnetizing cut-off frequency	0% to 100%	10%	★	F419
F4-26	Pre-excitation time	0s to 5s	0.1s	★	F41A
F4-27	Synchronous motor initial position recognition enable selection	0: Tested every time 1: No testing 2: Power-on first start-up detection	0 (recommended to be tested every time)	★	F41B
F4-28	Initial voltage value for synchronous motor position recognition	30.0% to 130.0%	80%	★	F41C
F4-29	Carrier frequency setting at SVC startup	2.0K to F0-26	2.0K	★	F41D

Function code	Parameter Name	Element	Default	Property	Address
F4-30	Synchronous motor weak magnetic mode	0: weak magnetic frequency adjustment 1: automatic adjustment 2: feed-forward plus automatic adjustment	1	★	F41E
F4-31	Synchronous motor weak magnetic coefficient	0 to 50	5	★	F41F
F4-32	Integral coefficient of weak magnetism for synchronous motors	0 to 10 (Increasing F4-31 and F4-32 increases the weak magnetic response speed)	2	★	F420
F4-33	Synchronous motor output voltage saturation margin	1% to 50% (the higher the value, the easier it is to enter a weak magnetic mode)	5%	★	F421
F4-34	Synchronous Motor Convexity Gain Coefficient	50 to 500	100	★	F422
F4-35	Synchronous motor SVC speed filter coefficients	10 to 1000	100	★	F423
F4-42	On-line tuning enable	0:Close 1:Tuning before powering up for the first run 2:Pre-teen tuning	0	★	F42A

Function code	Parameter Name	Element	Default	Property	Address
F4-43	Synchronous motor on-line counter electromotive force identification	0:Off 1:On	0	★	F42B
F4-57	Synchronous motor initial position compensation angle	0.0° ~359.9°	0.0°	★	F439
<b>Group F5 - Input terminals</b>					
F5-00	X1 (DI1) terminal function	0: No function 1: Positive rotation operation (FWD) 2: Reverse operation (REV) 3: Three-wire operation control	1	★	F500
F5-01	X2 (DI2) terminal function	4: Forward Jogging (FJOG) 5: Reverse Jog (RJOG)	2	★	F501
F5-02	X3 (DI3) Terminal Function	6: Terminal UP 7: Terminal DOWN 8: Free parking	9	★	F502
F5-03	X4 (DI4) terminal function	9: Fault reset (RESET) 10: Running pause	12	★	F503

Function code	Parameter Name	Element	Default	Property	Address
F5-04	X5 (DI5) Terminal Function	11: External fault normally open input 12: Multi-segment command terminal 1 13: Multi-segment command terminal 2 14: Multi-segment command terminal 3 15: Multi-segment command terminal 4	13		F504
F5-05	X6 (DI6) terminal function	16: Acceleration and deceleration selection terminal 1 17: Acceleration and deceleration selection terminal 2 18: Frequency source switching 19: UP/DOWN setting clear (terminal, keypad) 20: Operation command switching terminal	0	★	F505
F5-06	X7 (DI7) terminal function	21: Acceleration/deceleration prohibition 22: PID failure (pause) 23: PLC status reset 24: Pendulum Pause 25: Timed Trigger Inputs 26: Immediate DC braking	0		F506

Function code	Parameter Name	Element	Default	Property	Address
		27: External fault normally closed input 28: Counter input 29: Counter Reset 30: Length Count Inputs 31: Length count reset 32: Torque control disabled 33: PULSE (pulse) frequency input 34: Frequency Modification Prohibition 35: Reverse direction of PID action 36: External parking terminal 1 37: Control command switching terminal 2 38: PID integral pause terminal 39: Frequency source X and preset frequency switching terminal 40: Frequency source Y and preset frequency switching terminal 41: Switching between motor 1 and motor 2 42: Reservations 43: PID parameter switching terminal			

Function code	Parameter Name	Element	Default	Property	Address
		44: Speed control/torque control switching 45: Emergency stops 46: External parking terminal 2 47: Deceleration DC braking 48: This run time is cleared to zero 49: Two-wire/three-wire switching 50: Prohibition of inversion 51: User-defined fault 1 52: User-defined faults 2 53: Sleep input			
F5-10	X(DI) terminal filter time	0.000 to 1.000s	0.010s	☆	F50A
F5-11	Terminal command method	0: 2-wire 1 1: 2-wire 2 2: 3-wire 1 3: 3-wire 2	0	★	F50B
F5-12	Terminal UP/DOWN change rate	0.01Hz/s to 100.00Hz/s	1.00 Hz/s	☆	F50C

Function code	Parameter Name	Element	Default	Property	Address
F5-13	Terminal valid logic 1	0: High level 1: Low level Single digit: DI1 (X1); Tenth digit: DI2 (X2); Hundred: DI3 (X3); Thousand: DI4 (X4); Ten thousand: DI5 (X5)	00000	★	F50D
F5-15	AI1 minimum input value	0.00V to 10.00V	0.00V	☆	F50F
F5-16	AI1 minimum input setting	-100.0% to 100.0%	0.0%	☆	F510
F5-17	AI1 maximum input value	0.00V to 10.00V	10.00V	☆	F511
F5-18	AI1 maximum input setting	-100.0% to 100.0%	100.0%	☆	F512
F5-19	AI1 input filter time	0.00s to 10.00s	0.10s	☆	F513
F5-20	AI2 minimum input value	0.00V to 10.00V	0.00V	☆	F514
F5-21	AI2 minimum input setting	-100.0% to 100.0%	0.0%	☆	F515
F5-22	AI2 maximum input value	0.00V to 10.00V	10.00V	☆	F516
F5-23	AI2 maximum input setting	-100.0% to 100.0%	100.0%	☆	F517
F5-24	AI2 input filter time	0.00s to 10.00s	0.10s	☆	F518

Function code	Parameter Name	Element	Default	Property	Address
F5-30	PULSE Input Minimum Frequency	0.00kHz~50.00kHz	0.00kHz	☆	F51E
F5-31	PULSE input minimum frequency setting	-100.0% to 100.0%	0.0%	☆	F51F
F5-32	PULSE Input Maximum Frequency	0.00kHz~50.00KHz	50.00kHz	☆	F520
F5-33	PULSE (pulse) input max. frequency setting	-100.0% to 100.0%	0.0%	☆	F521
F5-34	PULSE input filter time	0.00s to 10.00s	0.10s	☆	F522
F5-35	X1 (DI1) turn-on delay time	0.0s~3600.0s	0.0s	☆	F523
F5-36	X1 (DI1) disconnection delay time	0.0s~3600.0s	0.0s	☆	F524
F5-37	X2 (DI2) turn-on delay time	0.0s~3600.0s	0.0s	☆	F525
F5-38	X2 (DI2) disconnection delay time	0.0s~3600.0s	0.0s	☆	F526
F5-39	X3 (DI3) turn-on delay time	0.0s~3600.0s	0.0s	☆	F527
F5-40	X3 (DI3) disconnection delay time	0.0s~3600.0s	0.0s	☆	F528
F5-41	A11 as X (DI) terminal function selection	0 to 53, same function as normal DI (X) terminal	0	★	F529
F5-42	A12 as X(DI) terminal function selection	0 to 53, same function as normal DI (X) terminal	0	★	F52A

Function code	Parameter Name	Element	Default	Property	Address
F5-44	Valid mode selection when AI is used as the X (DI) terminal	Single digit, AI1: 0: active high, 1: active low Ten digits, AI2: 0: active high, 1: active low	0x00	☆	F52C
F5-45	AI curve selection	AI Multi-Point Curve Selection. Single digit: AI1 0: 2-point straight line F5-15~ F5-19 1: Multi-point curve 1: FE-00~ FE-07 2: Multi-point curve 2: FE-08~ FE-15 Ten digits: AI2 0: 2-point straight line F5-20~ F5-24 1: Multi-point curve 1: FE-00~ FE-07 2: Multi-point curve 2: FE-08~ FE-15	0x00	☆	F52D
F5-46	AI signal input type selection	Single digit: AI1, Ten digits: AI2 0: Voltage type, 1: Current type	00	☆	F52E
F5-47	Valid mode for X(DI) terminal in 2-wire 1 mode	0: level active, 1: pulse active	0	☆	F52F

Function code	Parameter Name	Element	Default	Property	Address
<b>Group F6 - Output terminals</b>					
F6-00	Control board relay RELAY1 output selection (TA TB TC relay, TA TB normally closed, TA TC normally open)	0: no output 1: Inverter running signal (RUN) 2: Fault output 3: Frequency level detection FdT1 arrival	2	☆	F600

Function code	Parameter Name	Element	Default	Property	Address
F6-01	Control board relay RELAY2 output selection (RA RB RC relay, RA RB normally closed, RA RC normally open)	4: Frequency Arrival (FAR) 5: Zero speed in operation 6: Motor overload pre-warning 7: Inverter overload pre-warning 8: PLC cycle completed 9: Accumulated runtime reached 10: Frequency limit in progress 11: Ready to run 12: AI1 > AI2 13: Upper limit frequency reached 14: Lower frequency limit reached 15: Under-voltage status output 16: Communication settings 17: Timer outputs 18: Reverse in operation 19: Reserved 20: Set length reached 21: Torque limit in progress 22: Current 1 arrives 23: Frequency 1 arrives 24: Module temperature	1	☆	F601

Function code	Parameter Name	Element	Default	Property	Address
		reached 25: Load off in progress 26: Cumulative power-up time reached 27: Timed arrival output 28: This running time arrives 29: Set count value reached 30: Designated count value reached 31: Motor 1, Motor 2 indication 32: Brake control output 33: Operating at zero speed2 34: Frequency Level Detection FdT2 Arrival 35: Zero current state 36: Software current overrun 37: Lower frequency limit reached, stop also outputs 38: Alarm output 39: Reserved 40: All input overrun 41: Reserved 42: Reserved 43: Frequency reaches 2 44: Current Reach 2 45: Fault Output			

Function code	Parameter Name	Element	Default	Property	Address
		51: Valid synchronised output of the start signal terminal 52: Effective synchronized output of the tap signal terminals			
F6-04	FM/Y1 terminal output method selection	0: Pulse output (FMP) 1: Open collector switching output (FMR)	1	☆	F604
F6-05	FM/Y1 output function selection	Same as relay 1 output selection	1	☆	F605
F6-09	AO1 output selection	0: Operating frequency	0	☆	F609
F6-10	AO2 output selection	1: Setting frequency 2: Output current 3: Output power	0	☆	F60A

Function code	Parameter Name	Element	Default	Property	Address
F6-11	FMP Output Selection	4: Output voltage 5: Analogue AI1 input value 6: Analogue AI2 input value 7: Communication setting 8: Output torque 9: Length 10: Count value 11: Motor speed 12: Bus-bar voltage (0 to 3 times the rated voltage of the inverter) 13: Pulse input 14: Output current 15: Output voltage (100.0% corresponds to 1000.0V) 16: Output torque (actual torque -2 times rated to 2 times rated)			F60B
F6-12	FMP Output Maximum Frequency	0.01kHz~100.00kHz	50.00kHz	☆	F60C
F6-13	AO1 output lower limit	-100.0% to F6-15	0.0%	☆	F60D
F6-14	Lower limit corresponds to AO1 output	0.00V to 10.00V	0.00V	☆	F60E
F6-15	AO1 output limit	F6-13 to 100.0%	100.0 %	☆	F60F
F6-16	Upper limit corresponds to AO1 output	0.00 to 10.00V	10.00V	☆	F610

Function code	Parameter Name	Element	Default	Property	Address
F6-17	AO2 output lower limit	-100.0% to F6-19	0.0%	☆	F611
F6-18	Lower limit corresponds to AO2 output	0.00V to 10.00V	0.00V	☆	F612
F6-19	AO2 output limit	F6-17 to 100.0%	100.0%	☆	F613
F6-20	Upper limit corresponds to AO2 output	0.00 to 10.00V	10.00V	☆	F614
F6-22	Main Relay RELAY1 Closing Delay	0.0s~3600.0s	0.0s	☆	F616
F6-23	Main relay RELAY2 closure delay	0.0 to 3600.0S	0.0s	☆	F617
F6-25	Y1 high output delay	0.0 to 3600.0S	0.0s	☆	F619
F6-26	Main relay RELAY1 disconnection delay time	0.0s~3600.0s	0.0s	☆	F61A
F6-27	Main relay RELAY2 disconnection delay time	0.0 to 3600.0S	0.0s	☆	F61B
F6-29	Y1 low output delay	0.0 to 3600.0S	0.0s	☆	F61D
F6-31	Reserved		00	☆	F61F
<b>Group F7 - Auxiliary Functions and Keypad Display</b>					
F7-00	Tap operation frequency	0.00Hz to maximum frequency	6.00 Hz	☆	F700
F7-01	Tap acceleration time	0.0s~3000.0s	10.0s	☆	F701
F7-02	Tap deceleration time	0.0s~3000.0s	10.0s	☆	F702
F7-03	Acceleration time 2	0.0s~3000.0s	10.0s	☆	F703
F7-04	Deceleration time 2	0.0 to 3000.0s	10.0s	☆	F704

Function code	Parameter Name	Element	Default	Property	Address
F7-05	Acceleration time 3	0.0 to 3000.0s	10.0s	☆	F705
F7-06	Deceleration time 3	0.0 to 3000.0s	10.0s	☆	F706
F7-07	Acceleration time 4	0.0 to 3000.0s	10.0s	☆	F707
F7-08	Deceleration time 4	0.0 to 3000.0s	10.0s	☆	F708
F7-09	Jump Frequency 1	0.00Hz to maximum frequency	0.00Hz	☆	F709
F7-10	Jump frequency1 amplitude	0.00Hz to maximum frequency	0.00Hz	☆	F70A
F7-11	Jump Frequency 2	0.00Hz to maximum frequency	0.00Hz	☆	F70B
F7-12	Jump frequency 2 amplitude	0.00Hz to maximum frequency	0.00Hz	☆	F70C
F7-14	Keyboard Knob Enable	0: Invalid (realized via F0-11) 1: Enable	1	☆	F70D
F7-15	Forward and reverse dead time	0.0s~3000.0s	0.2s	☆	F70F
F7-16	Keyboard Knob Accuracy	0:Default mode 1:0.1HZ 2: 0.5HZ 3: 1HZ 4: 2HZ 5: 4HZ 6: 5HZ 7: 8HZ 8: 10HZ	2	☆	F710

Function code	Parameter Name	Element	Default	Property	Address
F7-17	Frequency below lower limit frequency handling	0: Operate at the lower frequency limit 1: Stop the machine 2: Zero speed operation	0	☆	F711
F7-18	sagging rate	0.0% to 100.0%	0.0%	☆	F712
F7-19	Delay time for frequency below lower limit shutdown	0.0s to 600.0s	0.0s	☆	F713
F7-20	Setting the cumulative running time	0h~65000h	0h	☆	F714
F7-21	pointing priority	0: Invalid 1: Tap priority mode 1 2: Tap Priority Mode 2 1) Tapping is still effective in case of user failure or PID loss failure 2) The shutdown mode and DC braking can be set, and the JOG key of the panel is effective under any command source.	1	☆	F715
F7-22	Frequency detection value (FdT1 level)	0.00Hz to maximum frequency	50.00 Hz	☆	F716
F7-23	Frequency check hysteresis value (FdT1 hysteresis)	0.0% to 100.0%	5.0%	☆	F717
F7-24	Frequency Reach Detection Width	0.0% to 100.0%	0.0%	☆	F718
F7-25	Reserved		0	●	F719

Function code	Parameter Name	Element	Default	Property	Address
F7-26	Fan control	0: Fan running continuously 1: Fan running during inverter operation (Fan operates under shutdown when temperature is above 40° )	1	★	F71A
F7-27	STOP/RESET function	0: valid only for keyboard control 1: Stop or reset function active in all control modes	1	☆	F71B
F7-28	Quick /JOG key function selection	0: Forward Tap 1: Forward and Reverse Toggle 2: Reverse Tap 3: Panel and Remote Control Switching	0	★	F71C

Function code	Parameter Name	Element	Default	Property	Address
F7-29	LED operation display	0000 to 0xffff (hexadecimal number) 0000 to 0xffff Bit00: Operating frequency 0001 Bit01: Set frequency 0002 Bit02: Bus voltage 0004 Bit03: Output voltage 0008 Bit04: Output current 0010 Bit05: Output power 0020 Bit06: DI (X) Input Status 0040 Bit07: DO Output Status 0080 Bit08: AI1 Voltage 0100 Bit09: AI2 Voltage 0200 Bit10: PID setpoint 0400 Bit11: PID feedback value 0800 Bit12: Count value 1000 Bit13: Length value 2000 Bit14: Load speed display 4000	H.441F	☆	F71D

Function code	Parameter Name	Element	Default	Property	Address
F7-30	LED operating display parameter 2	0x0 to 0x1FF Bit00: Target torque % 0001 Bit01: Output torque % 0002 Bit02: Pulse Input pulse frequency (KHz) 0004 Bit03: DI7 (X7) High-speed Pulse Sampling Line Speed (m/min) 0008 Bit04: Motor speed (rpm) 0010 Bit05: AC inlet current (A) 0020 Bit06: Accumulated running time (h) 0040 Bit07: Current running time (min) 0080 Bit08: Cumulative power consumption (kWh) 0100 Bit09 to Bit15: Reserved	0x10	☆	F71E

Function code	Parameter Name	Element	Default	Property	Address
F7-31	LED stop display	1 to 0x1fff (hexadecimal number) Bit00: Set frequency 0001 Bit01: Bus voltage 0002 Bit02: DI (X) input status 0004 Bit03: DO output status 0008 Bit04: AI1 Voltage 0010 Bit05: AI2 Voltage 0020 Bit06: PID setpoint 0040 Bit07: PID Feedback Value 0080 Bit08: Count value 0100 Bit09: Length value 0200	H.0043	☆	F71F
F7-31	LED stop display	Bit10: Load speed display 0400 Bit11: PLC Phase 0800 Bit12: Input pulse frequency 1000 Bit13 ~ Bit15: Reserved	H.0043	☆	F71F
F7-32	Load Speed Display Factor	0.001 to 655.00	1.000	☆	F720

Function code	Parameter Name	Element	Default	Property	Address
F7-33	Radiator temperature	12°C ~ 100°C	Measured value	●	F721
F7-34	Cumulative power-up time	0h~65535h	Measured value	●	F722
F7-35	Cumulative running time	0h~65535h	Measured value	●	F723
F7-37	Current Run Timing Enable Selection	0: not enabled 1: enabled	0	★	F725
F7-38	Current Run Timing Time Source Selection	0: Digital setting F7-39 1: AI1 2: AI2(AI at 100%F7-39)	0	★	F726
F7-39	Current sub-run time setting	0.0min~6500.0min	0.0min	☆	F727
F7-40	High Level Timing Time	0.0s~6000.0s	2.0s	☆	F728
F7-41	Low Level Timing Time	0.0s~6000.0s	2.0s	☆	F729
F7-42	Activation of the protection function	0:Invalid (start terminal command valid for direct start) 1: Effective	1	☆	F72A
F7-44	Frequency reaches detection value 1	0.00Hz to F0-14	50.00 Hz	☆	F72C
F7-45	Frequency Detection Value 1 Arrival Width	0.0% to 100.0%	0.0%	☆	F72D
F7-46	Current reaches detection value 1	0.0% to 300.0%	100.0%	☆	F72E

Function code	Parameter Name	Element	Default	Property	Address
F7-47	Current detection value 1 arrives at the width	0.0% to 300.0%	0.0%	☆	F72F
F7-50	User password	0 to 65535	0	☆	F732
F7-51	Effectiveness of jump frequency during acceleration and deceleration	0: not valid 1: valid	0	☆	F733
F7-52	Setting the power-up arrival time	0h~65530h	0h	☆	F734
F7-54	Acceleration time 1/2 switching frequency point	0.00Hz to maximum frequency (F0-14)	0.00Hz	☆	F736
F7-55	Deceleration time 1/2 switching frequency point	0.00Hz to maximum frequency (F0-14)	0.00Hz	☆	F737
F7-56	Frequency detection value (FdT2 level)	0.00Hz to maximum frequency (F0-14)	50.00 Hz	☆	F738
F7-57	Frequency detection FdT2 hysteresis value	0.0% to 100.0%	5.0%	☆	F739
F7-58	Frequency reaches detection value 2	0.00Hz to maximum frequency (F0-14)	50.00 Hz	☆	F73A
F7-59	Frequency reach detection 2 amplitude	0.0% to 100.0%	0.0%	☆	F73B
F7-60	Zero current detection value	0.0% to 300.0%	10.0%	☆	F73C

Function code	Parameter Name	Element	Default	Property	Address
F7-61	Zero current detection delay time	0.01s~300.00s	1.00s	☆	F73D
F7-62	Output current amplitude detection	20.0% to 400.0%	200.0%	☆	F73E
F7-63	Output current amplitude detection delay time	0.00s~300.00s	0.00s	☆	F73F
F7-64	Current reaches detection value 2	20.0% to 300.0%	100.0%	☆	F740
F7-65	Current arrival detection 2 amplitude	0.0% to 300.0%	0.0%	☆	F741
F7-67	All input voltage lower limit	0.00V to F7-68	2.00V	☆	F743
F7-68	All input voltage upper limit	F7-67 to 11.00V	8.00V	☆	F744
F7-69	Module temperature reaches	0°C ~90°C	70°C	☆	F745
F7-70	Output power display correction factor	0.001 to 3.000	1.000	☆	F746
F7-71	Linear velocity display correction factor	Line speed = F7-71* number of HDI7 (HX7) pulses sampled per second/FB-07	1.000	☆	F747
F7-72	Motor speed display correction factor	0.0010 to 3.0000	1.0000	☆	F748
F7-73	Cumulative power consumption (kWh)	0 to 65535	Measured value	●	F749

Function code	Parameter Name	Element	Default	Property	Address
F7-74	Performance Software Versions	Performance Software Version Number	#. #.	●	F74A
F7-75	Functional Software Version	Functional software version number	#. #.	●	F74B
F7-76	Enhanced Function Parameter Display Selection	0: Hide Enhanced Function Parameter Group: C1 to C3 1: Display Enhanced Function Parameter Group: C1 to C3	1	☆	F74C
F7-77	Acceleration time 5	0.0 to 3000.0s	10.0s	☆	F74D
F7-78	Deceleration time 5	0.0 to 3000.0s	10.0s	☆	F74E
F7-79	Acceleration time 6	0.0 to 3000.0s	10.0s	☆	F74F
F7-80	Deceleration time 6	0.0 to 3000.0s	10.0s	☆	F750
F7-81	Acceleration time 7	0.0 to 3000.0s	10.0s	☆	F751
F7-82	Deceleration time 7	0.0 to 3000.0s	10.0s	☆	F752
F7-83	Acceleration time 8	0.0 to 3000.0s	10.0s	☆	F753
F7-84	Deceleration time 8	0.0 to 3000.0s	10.0s	☆	F754
<b>Group F8 - Communication Parameters</b>					

Function code	Parameter Name	Element	Default	Property	Address
F8-00	Baud rate setting	0: 300BPS 1: 600BPS 2: 1200BPS 3: 2400BPS 4: 4800BPS 5: 9600BPS 6: 19,200 BPS 7: 38,400 BPS 8:57600BPS 9:115200BPS	5	☆	F800
F8-01	Data format	0: no checksum <8,N,2> 1: even checksum <8,E,1> 2: odd checksum <8,O,1> 3: no checksum 1 <8,N,1>	0	☆	F801
F8-02	Mail address	0 to 247(0 is the broadcast address)	1	☆	F802
F8-03	Response time	0ms to 30ms	2ms	☆	F803
F8-04	Communication timeout	0.0s to 30.0s	0.0s	☆	F804
F8-05	Communication format selection	0: Standard Modbus RTU protocol 1: Non-standard ModBus RTU protocols	0	☆	F805
F8-06	Background software monitoring function	0: Disable, default 485 communication function 1:Open-background software monitoring function, at this time 485 communication function can not be used	0	☆	F806

Function code	Parameter Name	Element	Default	Property	Address
F8-07	Communication current resolution	0:0.01A 1:0.1A	0	☆	F807
F8-08	Communication readout frequency resolution	0: controlled by F0-20 1: 0.1 Hz 2: 0.01 Hz	0	☆	F808
<b>Group F9 - Faults and Protection</b>					
F9-00	Motor overload protection options	0: Prohibited 1: Allowed	1	☆	F900
F9-01	Motor overload protection gain	0.20 to 10.00 (1.0 ex works up to 185kW, 0.8 above 200kW)	Determination of model	☆	F901
F9-02	Motor overload warning factor (%)	50% to 100%	80%	☆	F902
F9-03	Over-voltage stall protection gain	000 to 100	030	☆	F903
F9-04	Over-voltage stall protection voltage	200.0 to 850.0V	760.0V	★	F904
F9-05	VF over loss speed protection gain	0 to 100	20	☆	F905
F9-06	VF over-current stall protection current	100% to 200%	150%	★	F906
F9-07	VF Weak magnetic area current stall protection factor	50% to 200%	100%	★	F907
F9-08	Over-pressure Stall Allowable Rise Limit	0.0% to 100.0%	10.0%	☆	F908

Function code	Parameter Name	Element	Default	Property	Address
F9-11	Failure auto reset times	0 to 20	0	☆	F90B
F9-12	Fault relay action selection during automatic fault reset	0: Non action 1: Action	0	☆	F90C
F9-13	Fault auto reset interval	0.1s to 100.0s	1.0s	☆	F90D
F9-14	Input out-of-phase enable selection	0: not valid 1: valid	1	☆	F90E
F9-15	Output out-of-phase enable selection	Asynchronous machine: 0: invalid 1: valid Synchronize: Bit: Output out-of-phase detection Ten bits: Output phase loss detection before operation	01	☆	F90F
F9-16	Uplink to ground short circuit protection selection	0: not valid 1: valid	1	☆	F910
F9-17	Automatic reset option for under-voltage faults	0: Manual reset fault required after under-voltage faults 1: Self-resetting faults according to bus voltage after under-voltage faults	0	☆	F911

Function code	Parameter Name	Element	Default	Property	Address
F9-18	Over-voltage suppression mode selection	0: Invalid 1: Over-voltage suppression mode 1 2: Over-voltage suppression mode 2	1	★	F912
F9-19	Over-excitation active state selection	0: Invalid 1: Constant speed during operation, deceleration process effective 2: Valid only during deceleration	2	★	F913
F9-20	Over-voltage suppression mode 2 limit value	1.0%~ 150.0%	100.0%	★	F914
F9-21	Brake unit protection time	0.0s~ 200.0s	0.0s	★	F915
F9-22	Fail-safe action 1	0 to 22202; Bit: Motor overload - Err14 0: Free stop 1: Stop as per stopping mode 2: Keep running Tenth place: reserved Hundredths: Input out of phase-Err23 Thousand bits: Output out of phase - Err24 10,000 bits: parameter read/write exception-Err25	00000	☆	F916

Function code	Parameter Name	Element	Default	Property	Address
F9-23	Fail-safe action 2	0 to 22222; Bit: Communication Failure-Err27 0: Free stop 1: Stop as per stopping mode 2: Keep running Tenth position: external fault-Err28 Hundredths: Speed deviation too large fault-Err29 Thousands: User-defined Fault 1-Err30 10,000 bits: user-defined fault 2-Err31	00000	☆	F917

Function code	Parameter Name	Element	Default	Property	Address
F9-24	Fail-safe action 3	0 to 22022; Bit: Loss of PID feedback at runtime - Err32 0: Free stop 1: Stop as per stopping mode 2: Keep running Tenth position: Dropout fault-Err34 Hundred: reserved Thousand bits: current sub-continuous runtime reached -Err39 10,000 bits: running time up to -Err40	00000	☆	F918
F9-26	Frequency selection for continued operation in case of failure	0: Run at current operating frequency 1: Run at set frequency 2: Upper frequency operation 3: Operating at the lower frequency limit 4: Operation at standby frequency setting F9-27	1	☆	F91A
F9-27	Abnormal Standby Frequency Setting	0.0% to 100.0%	100.0%	☆	F91B
F9-28	Load shedding protection options	0: not valid 1: valid	0	☆	F91C
F9-29	Dropout detection level	0.0% to 80.0%	20.0%	★	F91D

Function code	Parameter Name	Element	Default	Property	Address
F9-30	Load shedding detection time	0.0s to 100.0s	5.0s	☆	F91E
F9-31	Excessive speed deviation detection value	0.0% to 100.0%	20.0%	☆	F91F
F9-32	Excessive speed deviation detection time	0.0s to 100.0s	0.0s	☆	F920
F9-33	Over speed detection value	0.0% to 100.0%	20.0%	☆	F921
F9-34	Over-speed detection time	0.0s to 100.0s	2.0s	☆	F922
F9-35	Motor overload protection current factor	100% to 200%	100%	☆	F923
F9-39	Under-voltage detection delay time	0.000s~1.000s	0.002s	☆	F927
F9-40	Output current amplitude detection1	20.0% to 400.0%	100.0%	☆	F928
F9-41	Output current amplitude detection delay time1	0.00s~300.00s	0.00s	☆	F929
<b>FA group - PID function</b>					
FA-00	PID given source	0: PID function code FA-01 1: AI1 2: AI2 3: Communication given 4: PULSE given 5: Multi-segment instruction given 6: Up/Down modification FA-01 (valid when F0-06=6)	0	☆	FA00

Function code	Parameter Name	Element	Default	Property	Address
FA-01	PID digital feed	0.0% to 100.0%	50.0%	☆	FA01
FA-02	PID given change time	0.00s to 650.00s	0.00s	☆	FA02
FA-03	PID Feedback Source	0: AI1 1: AI2 2: AI1-AI2 3: Communication Given 4: PULSE given 5: AI1+AI2 6: MAX( AI1 ,  AI2 ) 7: MIN( AI1 ,  AI2 )	0	☆	FA03
FA-04	Direction of PID action	0: positive 1: negative	0	☆	FA04
FA-05	PID feedback range	0 to 65535	1000	☆	FA05
FA-06	Proportional gain P	0.0~ 100.0	50.0	☆	FA06
FA-07	Integration time I	0.01s~ 10.00s	1.00s	☆	FA07
FA-08	Differential time D	0.000s~ 10.000s	0.000s	☆	FA08
FA-09	PID inversion cut-off frequency	0.00 to maximum frequency (F0-14)	0.00Hz	☆	FA09
FA-10	Deviation limit	0.0% to 100.0%	0.0%	☆	FA0A
FA-11	differential limiting	0.00% to 100.00%	0.10%	☆	FA0B
FA-12	PID feedback filtering time	0.00s~ 60.00s	0.00s	☆	FA0C
FA-13	PID feedback loss detection value	0.0% to 100.0%	0.0%	☆	FA0D
FA-14	PID feedback loss detection time	0.0s~3600.0s (0s not detected)	0.0s	☆	FA0E

Function code	Parameter Name	Element	Default	Property	Address
FA-15	PID given unit selection	0: % 1: Mpa	0	☆	FA0F
FA-16	PID feedback over limit detection value	0.0% to 100.0%	95.0%	☆	FA10
FA-17	PID feedback overrun detection time	0.0s~3600.0s (0s not detected)	0.0s	☆	FA11
FA-18	Proportional gain P2	0.0 to 100.0	20.0	☆	FA12
FA-19	Integration time I2	0.01s~ 10.00s	2.00s	☆	FA13
FA-20	Differential time D2	0.000s~ 10.000s	0.000s	☆	FA14
FA-21	PID parameter switching conditions	0: No switching 1: DI (X) terminal 2: Automatic switching according to deviation	0	☆	FA15
FA-22	PID parameter switching deviation1	0.0% to FA-23	20.0%	☆	FA16
FA-23	PID parameter switching deviation2	FA-22 to 100.0%	80.0%	☆	FA17
FA-24	PID initial value	0.0% to 100.0%	0.0%	☆	FA18
FA-25	PID initial value holding time	0.00s to 650.00s	0.00s	☆	FA19
FA-26	Positive maximum of two output deviations	0.00% to 100.00%	1.00%	☆	FA1A
FA-27	Two output deviation inverse max.	0.00% to 100.00%	1.00%	☆	FA1B

Function code	Parameter Name	Element	Default	Property	Address
FA-28	PID Integral Properties	Individuals: Separation of Points 0: not valid; 1: valid  Tenth position: output to the limit value, whether to stop integration  0: continue to count; 1: stop counting	00	☆	FA1C
FA-29	PID stopping operation	0: No calculation at shutdown  1: Calculation at shutdown	0	☆	FA1D
<b>FB Group - Pendulum Frequency, Fixed Length and Counting</b>					
FB-00	Oscillation setting method	0: Relative to the centre frequency 1: Relative to the maximum frequency	0	☆	FB00
FB-01	swing amplitude	0.0% to 100.0%	0.0%	☆	FB01
FB-02	Burst frequency amplitude	0.0% to 50.0%	0.0%	☆	FB02
FB-03	oscillation period	0.1s~3000.0s	10.0s	☆	FB03
FB-04	Triangular wave rise time coefficient	0.1% to 100.0%	50.0%	☆	FB04
FB-05	Setting length	0m to 65535m	1000m	☆	FB05
FB-06	Actual length	0m to 65535m	0m	☆	FB06
FB-07	Pulses per meter	0.1 to 6553.5	100.0	☆	FB07
FB-08	Setting the count value	1 to 65535	1000	☆	FB08

Function code	Parameter Name	Element	Default	Property	Address
FB-09	Specify the count value	1 to 65535	1000	☆	FB09
<b>FC Group - Multi-Segment Instructions and Simple PLC Functions</b>					
FC-00	Multi-speed 0	-100.0% to 100.0%	0.0%	☆	FC00
FC-01	Multi-speed 1	-100.0% to 100.0%	0.0%	☆	FC01
FC-02	Multi-speed 2	-100.0% to 100.0%	0.0%	☆	FC02
FC-03	Multi-speed 3	-100.0% to 100.0%	0.0%	☆	FC03
FC-04	Multi-speed 4	-100.0% to 100.0%	0.0%	☆	FC04
FC-05	Multi-speed 5	-100.0% to 100.0%	0.0%	☆	FC05
FC-06	Multi-speed 6	-100.0% to 100.0%	0.0%	☆	FC06
FC-07	Multi-Speed 7	-100.0% to 100.0%	0.0%	☆	FC07
FC-08	Multi-Speed 8	-100.0% to 100.0%	0.0%	☆	FC08
FC-09	Multi-Speed 9	-100.0% to 100.0%	0.0%	☆	FC09
FC-10	Multi-speed 10	-100.0% to 100.0%	0.0%	☆	FC0A
FC-11	Multi-speed 11	-100.0% to 100.0%	0.0%	☆	FC0B
FC-12	Multi-speed 12	-100.0% to 100.0%	0.0%	☆	FC0C
FC-13	Multi-speed 13	-100.0% to 100.0%	0.0%	☆	FC0D
FC-14	Multi-speed 14	-100.0% to 100.0%	0.0%	☆	FC0E
FC-15	Multi-speed 15	-100.0% to 100.0%	0.0%	☆	FC0F
FC-16	PLC operation mode	0: Shutdown at the end of a single run 1: Single run to maintain end value 2: Keep looping	0	☆	FC10

Function code	Parameter Name	Element	Default	Property	Address
FC-17	PLC power-down memory selection	0: no memory for power down and no memory for shutdown 1: Memory for power down and no memory for shutdown 2: No memory for power down and memory for shutdown 3: Power-down memory and shutdown memory	0	☆	FC11
FC-18	PLC segment 0 runtime	0.0 to 6500.0	0.0	☆	FC12
FC-19	PLC segment 0 plus or minus time selection	0 to 3 (indicates acceleration and deceleration times 1 to 4, respectively)	0	☆	FC13
FC-20	PLC segment 1 runtime	0.0 to 6500.0	0.0	☆	FC14
FC-21	PLC segment 1 add/drop time selection	0 to 3 (indicates acceleration and deceleration times 1 to 4, respectively)	0	☆	FC15
FC-22	PLC segment 2 runtime	0.0 to 6500.0	0.0	☆	FC16
FC-23	PLC segment 2 plus or minus time selection	0 to 3 (indicates acceleration and deceleration times 1 to 4, respectively)	0	☆	FC17
FC-24	PLC segment 3 runtime	0.0 to 6500.0	0.0	☆	FC18

Function code	Parameter Name	Element	Default	Property	Address
FC-25	PLC segment 3 plus or minus time selection	0 to 3 (indicates acceleration and deceleration times 1 to 4, respectively)	0	☆	FC19
FC-26	PLC segment 4 runtime	0.0 to 6500.0	0.0	☆	FC1A
FC-27	PLC segment 4 plus or minus time selection	0 to 3 (indicates acceleration and deceleration times 1 to 4, respectively)	0	☆	FC1B
FC-28	PLC segment 5 runtime	0.0 to 6500.0	0.0	☆	FC1C
FC-29	PLC segment 5 plus or minus time selection	0 to 3 (indicates acceleration and deceleration times 1 to 4, respectively)	0	☆	FC1D
FC-30	PLC segment 6 runtime	0.0 to 6500.0	0.0	☆	FC1E
FC-31	PLC segment 6 plus or minus time selection	0 to 3 (indicates acceleration and deceleration times 1 to 4, respectively)	0	☆	FC1F
FC-32	PLC segment 7 runtime	0.0 to 6500.0	0.0	☆	FC20
FC-33	PLC segment 7 plus or minus time selection	0 to 3 (indicates acceleration and deceleration times 1 to 4, respectively)	0	☆	FC21
FC-34	PLC segment 8 runtime	0.0 to 6500.0	0.0	☆	FC22

Function code	Parameter Name	Element	Default	Property	Address
FC-35	PLC segment 8 plus or minus time selection	0 to 3 (indicates acceleration and deceleration times 1 to 4, respectively)	0	☆	FC23
FC-36	PLC paragraph 9 runtime	0.0 to 6500.0	0.0	☆	FC24
FC-37	PLC paragraph 9 plus or minus time selection	0 to 3 (indicates acceleration and deceleration times 1 to 4, respectively)	0	☆	FC25
FC-38	PLC paragraph 10 runtime	0.0 to 6500.0	0.0	☆	FC26
FC-39	PLC paragraph 10 plus or minus time selection	0 to 3 (indicates acceleration and deceleration times 1 to 4, respectively)	0	☆	FC27
FC-40	PLC paragraph 11 runtime	0.0 to 6500.0	0.0	☆	FC28
FC-41	PLC paragraph 11 plus or minus time selection	0 to 3 (indicates acceleration and deceleration times 1 to 4, respectively)	0	☆	FC29
FC-42	PLC segment 12 runtime	0.0 to 6500.0	0.0	☆	FC2A
FC-43	PLC paragraph 12 plus or minus time selection	0 to 3 (indicates acceleration and deceleration times 1 to 4, respectively)	0	☆	FC2B

Function code	Parameter Name	Element	Default	Property	Address
FC-44	PLC paragraph 13 runtime	0.0 to 6500.0	0.0	☆	FC2C
FC-45	PLC paragraph 13 plus or minus time selection	0 to 3 (indicates acceleration and deceleration times 1 to 4, respectively)	0	☆	FC2D
FC-46	PLC paragraph 14 runtime	0.0 to 6500.0	0.0	☆	FC2E
FC-47	PLC paragraph 14 plus or minus time selection	0 to 3 (indicates acceleration and deceleration times 1 to 4, respectively)	0	☆	FC2F
FC-48	PLC paragraph 15 runtime	0.0 to 6500.0	0.0	☆	FC30
FC-49	PLC paragraph 15 plus or minus time selection	0 to 3 (indicates acceleration and deceleration times 1 to 4, respectively)	0	☆	FC31
FC-50	PLC runtime unit selection	0: s (second) 1: h (hour)	0	☆	FC32
FC-51	Multi-speed priority mode selection	0: Multi-speed not prioritized 1: Multi-speed prioritized	0	☆	FC33

Function code	Parameter Name	Element	Default	Property	Address
FC-52	Multi-speed acceleration and deceleration selection	priority and time	0	☆	FC34
		0: Acceleration/deceleration time 1 1: Acceleration/deceleration time 2 2: Acceleration and deceleration time 3 3: Acceleration and deceleration time 4			
FC-53	Multi-speed FC-00 to FC-15 unit selection		0	☆	FC35
		0: % 1: HZ			
FC-55	Multi-segment instruction 0 given way		0	☆	FC37
		0: Function code FC-00 given 1: AI1 2: AI2 3: PULSE pulse 4: PID 5: Preset frequency given (F0-11), UP/DOWN modifiable			
<b>Group Fd - Torque control</b>					

Function code	Parameter Name	Element	Default	Property	Address
Fd-00	Torque command source selection	0: Digital setting (Fd-01) 1: AI1 2: AI2 3: Communication given 4: PULSE pulse frequency setting 5: MIN(AI1,AI2) 6: MAX(AI1,AI2) (Option 1-6 full scale corresponds to Fd-01)	0	★	Fd00
Fd-01	Digital Torque Setting	-200.0% to 200.0%	150.0%	☆	Fd01
Fd-03	Maximum frequency of positive direction of torque control	0.00Hz to maximum frequency (F0-14)	50.00 Hz	☆	Fd03
Fd-04	Torque control reverse direction max. frequency	0.00Hz to maximum frequency (F0-14)	50.00 Hz	☆	Fd04
Fd-06	Torque command filter time	0.00s to 10.00s	0.00s	☆	Fd06
Fd-07	Torque mode frequency acceleration time	0.0s~1000.0s	10.0s	☆	Fd07
Fd-08	Torque mode frequency deceleration time	0.0s~1000.0s	10.0s	☆	Fd08
Fd-10	Speed/torque mode selection	0: Speed mode 1: Torque mode	0	★	Fd0A

Function code	Parameter Name	Element	Default	Property	Address
Fd-12	Torque control accuracy mode selection	0: Torque control mode 1 1: Torque control mode 2 (high torque control accuracy, sensitive to motor parameters)	0	★	Fd0C
<b>FE Group - AI Multi-point Curve Setting</b>					
FE-00	Curve 1 Minimum Input	-10.00V to FE-02	0.00V	☆	FE00
FE-01	Curve 1 Minimum Input Corresponding Setting	-100.0% to 100.0%	0.0%	☆	FE01
FE-02	Curve 1 Inflection Point 1 Input	FE-00 to FE-04	3.00V	☆	FE02
FE-03	Curve 1 Inflection Point 1 Input Corresponding Setting	-100.0% to 100.0%	30.0%	☆	FE03
FE-04	Curve 1 inflection point 2 input	FE-02 to FE-06	6.00V	☆	FE04
FE-05	Curve 1 Inflection Point 2 Input Corresponding Setting	-100.0% to 100.0%	60.0%	☆	FE05
FE-06	Curve 1 Maximum Input	FE-06 to 10.00	10.00V	☆	FE06
FE-07	Curve 1 Maximum Input Corresponding Setting	-100.0% to 100.0%	100.0%		FE07
FE-08	Curve 2 Minimum Input	-10.00 to FE-10	0.00V	☆	FE08
FE-09	Curve 2 Minimum Input Correspondence Setting	-100.0% to 100.0%	0.0%	☆	FE09

Function code	Parameter Name	Element	Default	Property	Address
FE-10	Curve 2 inflection point 1 input	FE-08 to FE-12	3.00V	☆	FE0A
FE-11	Curve 2 Inflection Point 1 Input Corresponding Setting	-100.0% to 100.0%	30.0%	☆	FE0B
FE-12	Curve 2 Inflection Point 2 Input	FE-10 to FE-14	6.00V	☆	FE0C
FE-13	Curve 2 Inflection Point 2 Input Corresponding Setting	-100.0% to 100.0%	60.0%	☆	FE0D
FE-14	Curve 2 Maximum Input	FE-12 to 10.00V	10.00V	☆	FE0E
FE-15	Curve 2 Maximum Input Corresponding Setting	-100.0% to 100.0%	100.0%	☆	FE0F
FE-24	A11 sets the jump point	-100.0% to 100.0%	0.0%	☆	FE18
FE-25	A11 sets the jump range	0.0% to 100.0%	0.5%	☆	FE19
FE-26	A12 sets the jump point	-100.0% to 100.0%	0.0%	☆	FE1A
FE-27	A12 sets the jump range	0.0% to 100.0%	0.5%	☆	FE1B
<b>FF Group - Manufacturer's Parameters</b>					
FF-00	Manufacturer's password	0 to 65535	*****	☆	FF00
<b>Group C0-Second motor parameter setting</b>					
C0-00	Motor Selection	1: Motor No. 1 2: Motor No. 2 (F7-76=1, showing groups C1 to C3)	1	★	B000

Function code	Parameter Name	Element	Default	Property	Address
C0-01	Second motor control method	1: Open-loop vector control (vector without speed sensor) 2: VF control	2	★	B001
C0-02	Second motor acceleration and deceleration time selection	0: In line with first motor 1: Acceleration and deceleration time 1 2: Acceleration and deceleration time 2 3: Acceleration and deceleration time 3 4: Acceleration and deceleration time 4	0	☆	B002
<b>Group C1 - second motor parameters</b>					
C1-00	Motor parameter tuning	0: No function 1: Static tuning 2: Dynamic full tuning	0	★	B100
C1-01	Motor2 Rated power	0.4 kW to 1000.0kW	Determination of model	★	B101
C1-02	Motor 2 rated voltage	0V to 1500V	380V	★	B102
C1-03	Motor 2 Number of motor poles	2 to 64	Determination of model	●	B103
C1-04	Motor 2 rated current	0.01A ~ 600.00A (motor rated power ≤30.0kW) 0.1A ~ 6000.0A (motor rated power >30.0kW)	C1-01 Determination	★	B104

Function code	Parameter Name	Element	Default	Property	Address
C1-05	Motor 2 Rated frequency	0.00Hz to maximum frequency (F0-14)	50.00 Hz	★	B105
C1-06	Motor 2 Rated speed	0rpm~3000rpm	C1-01 Determination	★	B106
C1-07	Motor 2 no-load current	0.01A to C1-04 (motor rated power <=30.0kW) 0.1A to C1-04 (motor rated power >30.0kW)	C1-01 Determination	★	B107
C1-08	Motor 2 stator resistance	0.001ohm~65.535ohm	Determination of model	★	B108
C1-09	Motor 2 rotor resistance	0.001ohm~65.535ohm	Determination of model	★	B109
C1-10	Motor 2 mutual inductive resistance	0.1mH~6553.5mH	Determination of model	★	B10A
C1-11	Motor 2 leakage inductive reactance	0.01mH~655.35mH	Determination of model	★	B10B
C1-12	Acceleration during dynamic full tuning	1.0s to 600.0s	10.0s	☆	B10C
C1-13	Deceleration during dynamic full tuning	1.0s to 600.0s	10.0s	☆	B10D
<b>Group C2 - Second motor VF parameter setting</b>					
C2-00	Torque Increase	0.0% to 30.0%	0.0%	☆	B200
C2-02	Oscillation suppression gain	0 to 100	Determination of model	☆	B202
<b>Group C3 - Second Motor Vector Control Parameters</b>					

Function code	Parameter Name	Element	Default	Property	Address
C3-00	Switching frequency F1	1.00 Hz to C3-02	5.00 Hz	☆	B300
C3-02	Switching frequency F2	C3-00 to B0-14	10.00 Hz	☆	B302
C3-04	Low frequency speed proportional gain	0.1 to 10.0	4.0	☆	B304
C3-05	Low Frequency Velocity Integration Time	0.01s~10.00s	0.50s	☆	B305
C3-06	High frequency speed proportional gain	0.1 to 10.0	2.0	☆	B306
C3-07	High Frequency Velocity Integration Time	0.01s~10.00s	1.00s	☆	B307
C3-08	Speed Ring Points Attribute Selection	0: Points in effect 1: Points separated	0	★	B308
C3-11	Torque current regulator Kp	0 to 30000	2000	☆	B30B
C3-12	Torque current regulator Ki	0 to 30000	1300	☆	B30C
C3-13	Excitation current regulator Kp	0 to 30000	2000	☆	B30D
C3-14	Excitation current regulator Ki	0 to 30000	1300	☆	B30E
C3-15	Flux Braking Gain	100 to 200	110	☆	B30F
C3-16	Weak magnetic torque correction factor	50% to 150%	100%	☆	B310
C3-17	Differential Compensation Factor	50% to 200%	100%	☆	B311

Function code	Parameter Name	Element	Default	Property	Address
C3-18	Velocity loop feedback filter time constant	0.000s~1.000s	0.015s	☆	B312
C3-19	Velocity loop output filter time constant	0.000s~1.000s	0.000s	☆	B313
C3-20	Electric Torque Limit Source	0: F4-21 1: AI1 (analogue range corresponds to F4-21) 2: AI2 3: Communication given 4: PLUSE given	0	☆	B314
C3-21	Upper limit of electric torque	0.0% to 200.0%	150.0%	☆	B315
C3-22	Braking torque upper limit source	0: F4-23 1: AI1 (analogue range corresponds to F4-23) 2: AI2 3: Communication given 4: PLUSE given	0	☆	B316
C3-23	Upper limit of braking torque	0.0% to 200.0%	150.0%	☆	B317
<b>Group E0 - system parameters</b>					
E0-00	Function Code Read-Only Selection	0: invalid 1: read-only	0	☆	C000

Function code	Parameter Name	Element	Default	Property	Address
E0-01	LCD top level menu display (Dual-display LED keypad line 2 shows digits E0-01)	The second line displays the variable (digits): 0: Output current 1: Motor speed 2: Load speed 3: Output voltage 4: PID given 5: PID feedback 6: Busbar voltage 7: Operating frequency The third line displays the variable (ten digits): 0: Output current 1: Motor speed 2: Load speed 3: Output voltage 4: PID given 5: PID feedback 6: Busbar voltage	10	☆	C001
E0-02	LCD language selection	0: Chinese 1: English	0	☆	C002
E0-03	LED menu switching selection	0: Disable 1: Enable	0	☆	C003
E0-04	Vector operating frequency display selection	0: Real-time frequency 1: Set frequency	0	☆	C004
E0-05	Display selection during UP/DOWN adjustment	0: Display set value 1: Display current variable value	0	☆	C005

Function code	Parameter Name	Element	Default	Property	Address
<b>Group E1 - User Function Code Customized</b>					
E1-00	Clear custom function code selection	0: not valid 1: valid	0	☆	C100
E1-01	Custom Function Code 1	uF0-00 to uU1-xx	uF0-03	☆	C101
E1-02	Custom Function Code 2	uF0-00 to uU1-xx	uF0-04	☆	C102
E1-03	Custom Function Code 3	uF0-00 to uU1-xx	uF0-06	☆	C103
E1-04	Custom Function Code 4	uF0-00 to uU1-xx	uF0-23	☆	C104
E1-05	Custom Function Code 5	uF0-00 to uU1-xx	uF0-24	☆	C105
E1-06	Custom Function Code 6	uF0-00 to uU1-xx	uF1-00	☆	C106
E1-07	Custom Function Code 7	uF0-00 to uU1-xx	uF1-01	☆	C107
E1-08	Custom Function Code 8	uF0-00 to uU1-xx	uF1-02	☆	C108
E1-09	Custom Function Code 9	uF0-00 to uU1-xx	uF1-04	☆	C109
E1-10	Customized function code 10	uF0-00 to uU1-xx	uF1-05	☆	C10A
E1-11	Custom Function Code 11	uF0-00 to uU1-xx	uF1-06	☆	C10B
E1-12	Custom Function Code 12	uF0-00 to uU1-xx	uF1-12	☆	C10C
E1-13	Custom Function Code 13	uF0-00 to uU1-xx	uF1-13	☆	C10D
E1-14	Custom Function Code 14	uF0-00 to uU1-xx	uF5-00	☆	C10E
E1-15	Custom Function Code 15	uF0-00 to uU1-xx	uF5-01	☆	C10F

Function code	Parameter Name	Element	Default	Property	Address
E1-16	Custom Function Code 16	uF0-00 to uU1-xx	uF5-02	☆	C110
E1-17	Custom Function Code 17	uF0-00 to uU1-xx	uF6-00	☆	C111
E1-18	Custom Function Code 18	uF0-00 to uU1-xx	uF6-01	☆	C112
E1-19	Custom Function Code 19	uF0-00 to uU1-xx	uF0-00	☆	C113
E1-20	Custom Function Codes 20	uF0-00 to uU1-xx	uF0-00	☆	C114
E1-21	Custom Function Code 21	uF0-00 to uU1-xx	uF0-00	☆	C115
E1-22	Custom Function Code 22	uF0-00 to uU1-xx	uF0-00	☆	C116
E1-23	Custom Function Code 23	uF0-00 to uU1-xx	uF0-00	☆	C117
E1-24	Custom Function Code 24	uF0-00 to uU1-xx	uF0-00	☆	C118
E1-25	Custom Function Code 25	uF0-00 to uU1-xx	uF0-00	☆	C119
E1-26	Custom Function Code 26	uF0-00 to uU1-xx	uF0-00	☆	C11A
E1-27	Custom Function Code 27	uF0-00 to uU1-xx	uF0-00	☆	C11B

Function code	Parameter Name	Element	Default	Property	Address
E1-28	Custom Function Code 28	uF0-00 to uU1-xx	uF0-00	☆	C11C
E1-29	Custom Function Code 29	uF0-00 to uU1-xx	uF0-00	☆	C11D
E1-30	Custom Function Codes 30	uF0-00 to uU1-xx	uF0-00	☆	C11E
E1-31	Custom Function Code 31	uF0-00 to uU1-xx	uF0-00	☆	C11F
<b>Group E2 - Optimization of control parameters</b>					
E2-00	Deadband compensation enable selection	0: No compensation 1: Compensation	1	☆	C200
E2-01	PWM method	0: Asynchronous modulation 1: Synchronous modulation	0	☆	C201
E2-02	PWM seven band/five band selection (G680S: PWM seven-band/five-band switching frequency)	0: Full seven-segment 1: Seven-segment/five-segment automatic switching (G680S: 1.00 HZ to F0-14)	0 (G680S: 8.00 HZ)	☆	C202
E2-03	CBC current limit enable selection	0: Disable 1: Enable	1	☆	C203
E2-04	braking point	350.0V to 780.0V	360.0V	☆	C204
			690.0V	☆	
E2-05	Under-voltage point	150.0V to 500.0V	200.0V	☆	C205
			350.0V	☆	

Function code	Parameter Name	Element	Default	Property	Address
E2-06	Random PWM depth setting	0 to 6	0	☆	C206
E2-07	0Hz operation mode selection	0: no current output; 1: normal operation; 2: Output with stopping DC braking current F2-16;	0	☆	C207
E2-08	Low-frequency carrier limiting method selection	0: Restricted mode 0 1: Restricted mode 1 2: Unlimited (consistent carrier in all frequency bands)	0	☆	C208
E2-12	VF high carrier enable	0: not enabled 1: enabled	0	★	C20C
E2-14	Synchronous motor initial position recognition minimum current	0% to 80% (in conjunction with F4-28)	50	☆	C20E
<b>Group E3 - AIAO calibration parameters</b>					
E3-00	A11 displays voltage 1	-9.999V to 10.000V	3.000V	☆	C300
E3-01	A11 measured voltage1	-9.999V to 10.000V	3.000V	☆	C301
E3-02	A11 display voltage 2	-9.999V to 10.000V	8.000V	☆	C302
E3-03	A11 measured voltage2	-9.999V to 10.000V	8.000V	☆	C303
E3-04	A12 display voltage 1	-9.999V to 10.000V	3.000V	☆	C304
E3-05	A12 measured voltage1	-9.999V to 10.000V	3.000V	☆	C305
E3-06	A12 display voltage 2	-9.999V to 10.000V	8.000V	☆	C306

Function code	Parameter Name	Element	Default	Property	Address
E3-07	AI2 measured voltage2	-9.999V to 10.000V	8.000V	☆	C307
E3-12	AO1 target voltage 1	-9.999V to 10.000V	3.000V	☆	C30C
E3-13	AO1 measured voltage1	-9.999V to 10.000V	3.000V	☆	C30D
E3-14	AO1 target voltage 2	-9.999V to 10.000V	8.000V	☆	C30E
E3-15	AO1 measured voltage2	-9.999V to 10.000V	8.000V	☆	C30F
E3-16	AO2 target voltage1	-9.999V to 10.000V	3.000V	☆	C310
E3-17	AO2 measured voltage1	-9.999V to 10.000V	3.000V	☆	C311
E3-18	AO2 target voltage 2	-9.999V to 10.000V	8.000V	☆	C312
E3-19	AO2 measured voltage2	-9.999V to 10.000V	8.000V	☆	C313
<b>Group E4 - Master-Slave Control Parameters</b>					
E4-00	Master-slave control enable selection:	0: Disable 1: Enable	0	★	C400
E4-01	Master-slave selection:	0: Master 1: Slave	0	★	C401
E4-02	Host transmit frequency selection:	0: Operating frequency 1: Target frequency	0	★	C402
E4-03	Slave Follows Master Command Source Selection	0: Do not follow 1: Follow	0	★	C403
E4-04	Slave receive frequency factor	0.0% to 6000.0%	100.0%	☆	C404
E4-05	Slave receiving torque factor	-10.00 to 10.00	1.00	☆	C405

Function code	Parameter Name	Element	Default	Property	Address
E4-06	Slave Receive Torque Bias	-50.00% to 50.00%	0.00%	☆	C406
E4-07	Frequency deviation threshold	0.20% to 10.00%	0.50%	☆	C407
E4-08	Master-slave communication drop detection time	0.00s to 10.0s	0.1s	☆	C408
E4-09	Slave receive frequency coefficient selection	Receive frequency gain selection 0: Function code setting (E4-04), 1: AI1; 2: AI2	0	☆	C409
<b>Group E5 - Functional parameters of holding brake</b>					
E5-00	Holding brake control enable selection:	0: Disable 1: Enable	0	★	C500
E5-01	Holding brake release frequency	0.00Hz to 20.00Hz	2.50Hz	★	C501
E5-02	Holding brake release frequency maintenance time	0.0s to 20.0s	1.0s	★	C502
E5-03	Current limit value during braking	50.0% to 200.0%	120.0%	★	C503
E5-04	Clamping frequency	0.00 Hz to 20.00 Hz	1.50 Hz	★	C504
E5-05	Holding brake suction delay time	0.0s to 20.0s	0.0s	★	C505

Function code	Parameter Name	Element	Default	Property	Address
E5-06	Holding frequency maintenance time	0.0s to 20.0s	1.0s	★	C506
E5-07	Loosening torque current detection value	0.0% to 100.0%	12.0%	★	C507
<b>Group E6 - Sleep Wake Function Parameters</b>					
E6-00	Hibernation Options	0: Hibernation function is disabled 1: Digital input terminal DI (X) control sleep function 2: Sleep function controlled by PID set value and feedback value 3: Control of sleep function according to operating frequency	0	☆	C600
E6-01	Sleeping frequency	0.00Hz to F0-14	0.00Hz	☆	C601
E6-02	sleep delay	0.0s~3600.0s	20.0s	☆	C602
E6-03	wake-up call difference	0.0% to 100.0% When E6-00=3, the unit becomes HZ	10.0%	☆	C603
E6-04	Wake-up delay	0.0s~3600.0s	0.5s	☆	C604
E6-05	Sleep delay frequency output selection	0: PID auto-tuning, 1: Dormant frequency E6-01	0	☆	C605
<b>n0 Group - Specialized Application Macros</b>					
n0-00	Application macro	0 to 11	00	☆	D000

Function code	Parameter Name	Element	Default	Property	Address
<b>n1 Group - Special function of constant pressure water supply</b> (Reserved, communication address D100~D10E)					
Function code	Parameter Name	Element	Default	Property	Address
<b>Group U0 - Fault Logging Parameters</b>					

Function code	Parameter Name	Element	Default	Property	Address
U0-00	Type of last failure	00: No fault Err01: Inverter module protection Err04: Over-current during acceleration Err05: Over-current during deceleration Err06: Over-current in constant speed operation Err08: Over-voltage during acceleration Err09: Over-voltage during deceleration Err10: Over-voltage during constant speed operation Err12: Under-voltage fault Err13: Drive overload fault Err14: Motor overload fault Err15: Drive overheating Err17: Current detection fault Err20: Short to ground fault Err23: Input out-of-phase fault Err24: Output out-of-phase fault Err25: Eeprom operation failure Err27: Communication failure Err28: External fault Err29: speed deviation Err30: User-defined fault 1	1	•	7000

Function code	Parameter Name	Element	Default	Property	Address
U0-01	Type of previous failure		1	●	7001
U0-02	Pre-secondary fault type		1	●	7002
U0-03	Frequency at last failure		0.01Hz	●	7003
U0-04	Current at last fault (note: CBC fault current, record ac current peak)		0.01A	●	7004
U0-05	Busbar voltage at last fault		0.1V	●	7005
U0-06	Input terminal status at last fault		1	●	7006
U0-07	Output terminal status at last fault		1	●	7007
U0-08	Last fault inverter status		1	●	7008
U0-09	Running time at last failure (minutes from power-up)		1min	●	7009
U0-10	Runtime at last failure (minutes from time of operation)		1min	●	700A
U0-13	Frequency at previous failure		0.01Hz	●	700D
U0-14	Current at previous fault		0.01A	●	700E
U0-15	Busbar voltage at previous fault		0.1V	●	700F
U0-16	Input terminals at previous fault		1	●	7010
U0-17	Output terminals at previous fault		1	●	7011

Function code	Parameter Name	Element	Default	Property	Address
U0-18	Previous fault inverter status		1	●	7012
U0-19	Running time at previous fault (power-on start time, minutes)		1min	●	7013
U0-20	Time at previous failure (minutes from time of operation)		1min	●	7014
U0-21	reserved variable			●	7015
U0-22	reserved variable			●	7016
U0-23	Frequency at first second failure		0.01Hz	●	7017
U0-24	Current at first secondary fault		0.01A	●	7018
U0-25	Busbar voltage at first secondary fault		0.1V	●	7019
U0-26	Input terminals in case of first secondary fault		1	●	701A
U0-27	Output terminals at first two faults		1	●	701B
U0-28	Former secondary fault inverter status		1	●	701C
U0-29	Running time at first two faults (power-on start time, minutes)		1min	●	701D
U0-30	Time at first second failure (minutes from time of operation)		1min	●	701E
<b>Group U1-Application Monitoring Parameters</b>					
U1-00	Operating frequency (HZ)		0.01Hz	●	7100
U1-01	Setting frequency (HZ)		0.01Hz	●	7101
U1-02	Busbar voltage (V)		0.1V	●	7102
U1-03	Output Voltage (V)		1V	●	7103

Function code	Parameter Name	Element	Default	Property	Address
U1-04	Output current (0.01A: power <=30.0kW, 0.1A: power >30.0kW)		Determination of model	●	7104
U1-05	Output power (kW)		0.1kW	●	7105
U1-06	DI (X) input status, hexadecimal number		1	●	7106
U1-07	DO output status, hexadecimal number		1	●	7107
U1-08	AI1 corrected voltage		0.01V	●	7108
U1-09	AI2 corrected voltage		0.01V	●	7109
U1-10	PID set value, PID set value (%)*FA-05		1	●	710A
U1-11	PID feedback, PID feedback value (percentage)*FA-05		1	●	710B
U1-12	numerical value		1	●	710C
U1-13	length value		1	●	710D
U1-14	Motor speed		rpm	●	710E
U1-15	PLC stage, current segment in multi-speed operation		1	●	710F
U1-16	PULSE pulse input frequency		0.01kHz	●	7110
U1-17	Feedback speed, actual motor operating frequency		0.1Hz	●	7111
U1-18	F7-39 Remaining time of timer time		0.1Min	●	7112
U1-19	AI1 voltage before correction		0.001V	●	7113
U1-20	AI2 voltage before correction		0.001V	●	7114
U1-21	DI7 (X7) High-speed pulse sampling line speed, refer to F7-71.		1m/min	●	7115
U1-22	Load speed display (set load speed at shutdown), refer to F7-32.		Customization	●	7116

Function code	Parameter Name	Element	Default	Property	Address
U1-23	Current power-up time		1Min	●	7117
U1-24	Time of this run		0.1Min	●	7118
U1-25	PULSE pulse input frequency, different from U1-16 only in units		1Hz	●	7119
U1-26	Communication set frequency value		0.01%	●	711A
U1-27	Main frequency display		0.01Hz	●	711B
U1-28	Auxiliary frequency display		0.01Hz	●	711C
U1-29	Target torque at 100% of rated motor torque		0.1%	●	711D
U1-30	Output torque at 100% of rated motor torque		0.1%	●	711E
U1-31	Output torque at 100% of the rated current of the inverter		0.1%	●	711F
U1-32	Upper torque limit at 100% of the rated current of the inverter		0.1%	●	7120
U1-33	VF Separation Target Voltage		1V	●	7121
U1-34	VF Separation Output Voltage		1V	●	7122
U1-35	reservation			●	7123
U1-36	Currently using motor serial number		1	●	7124
U1-37	AO1 target voltage		0.01V	●	7125
U1-38	AO2 target voltage		0.01V	●	7126
U1-39	Frequency converter operation status, 0: stop, 1: forward, 2: reverse, 3: failure		1	●	7127
U1-40	Current faults of the inverter		1	●	7128
U1-41	Agents Limited Time Remaining		1h	●	7129

Function code	Parameter Name	Element	Default	Property	Address
U1-42	AC Inlet Current		0.1A	●	712A
U1-43	Remaining time of the current phase of the PLC		0.1	●	712B
U1-47	Cumulative runtime1 (cumulative runtime = U1-47 + U1-48)		1h	●	712F
U1-48	Cumulative runtime2 (cumulative runtime = U1-47 + U1-48)		1min	●	7130
U1-74	carrier wave in effect		Depending on the model	●	714A

**G680 series part of the industry-specific machine application macro parameter table**  
(n0-00 communication address: D000):

serial number	Application Macro Parameter Settings	Product Serial Number	External specialized machine models
1	n0-00=0	F0-00=630.00	Common software
2	n0-00=1	F0-00=630.01	G631 (Circular Loom Application Macro)
3	n0-00=2	F0-00=630.02	G632 (machine tool application macros)
4	n0-00=3	F0-00=630.03	G633 (Whipcutter Application Macro)
5	n0-00=4	F0-00=630.04	G634 (incense maker application macro)
6	n0-00=8	F0-00=630.08	G638 (Lifting Industry/Construction Lift Application Macro)
7	n0-00=9	F0-00=630.09	G639 485 Communication Compatible

			with MD Series
8	n0-00=10	F0-00=630.10	G6310 LCD keypad constant pressure water supply application macro
9	n0-00=11	F0-00=630.11	G6311 LED keypad constant pressure water supply application macro



# Chapter 8 Motor Closed Loop Commissioning

## Instructions

### 8.1 Asynchronous motor closed-loop commissioning instructions

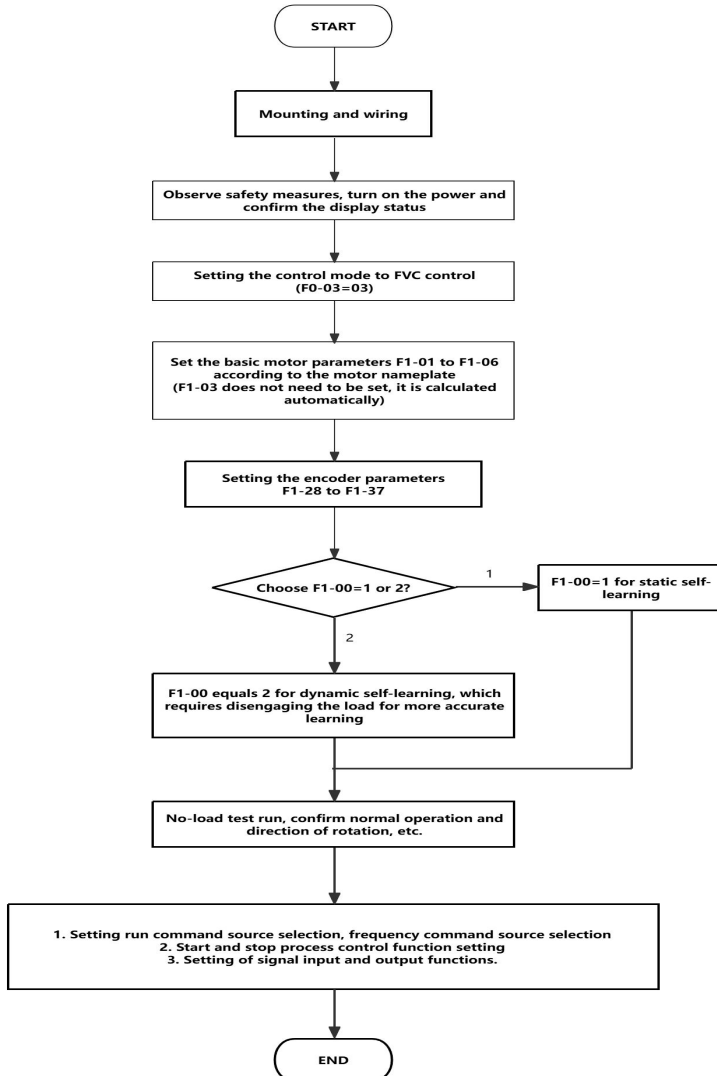

## 8.2 Closed-loop commissioning instructions for permanent magnet synchronous motors

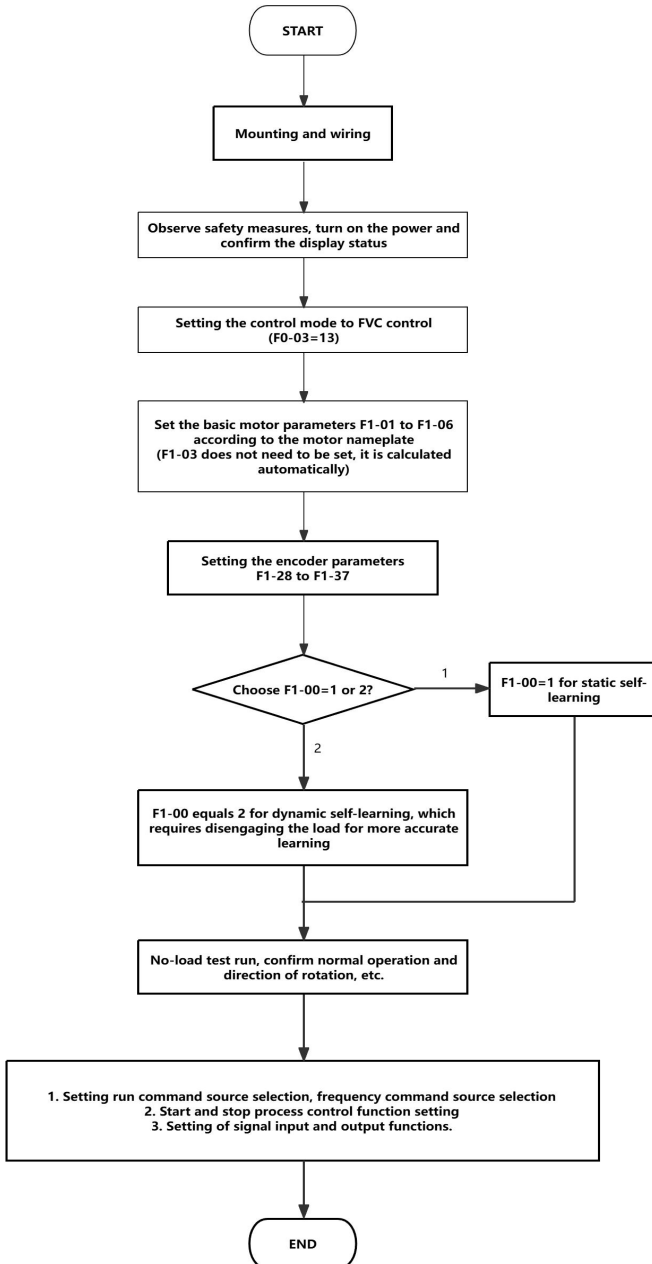

## Appendix A: Card Class Descriptions

## A. Expansion Card Installation Instructions

**1. Installation Notes:**

- 1) Please install it with the inverter completely powered off;
- 2) Align the expansion card connector and positioning holes of the expansion card and the inverter control board;
- 3) Secure with screws.

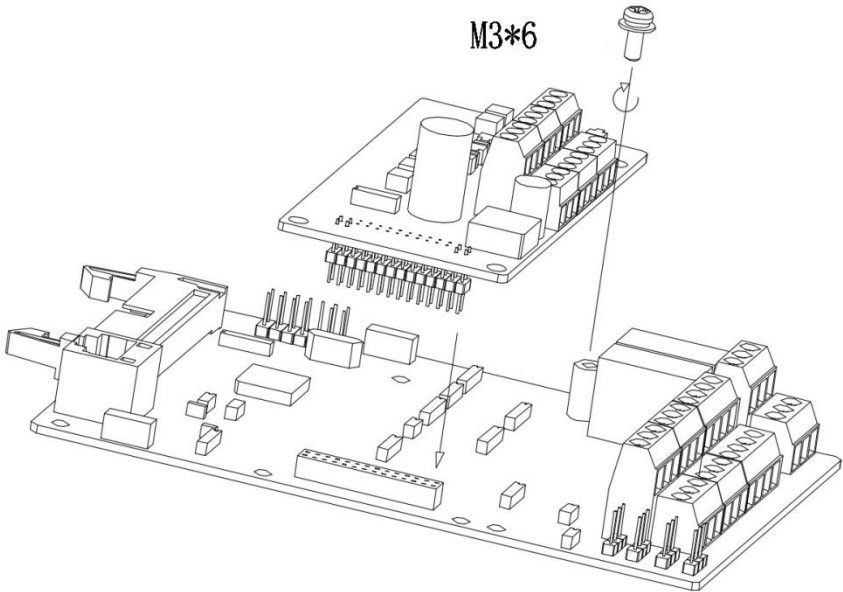

Appendix C: Figure1 G680/G680S Expansion Card Mounting Style

**B. Expansion card instructions**

**1. Overview:**

G680/G680S is equipped with three kinds of general-purpose encoder extension cards (i.e. PG cards), which are used as optional accessories and are mandatory for the inverter to do closed-loop vector control or closed-loop torque control, according to the form of encoder output to select the corresponding PG cards, the specific models are as follows:

Option Model	Descriptions
G680-PGO	Open collector signal (OC) input (complementary output compatible, NPN voltage output encoder, switchable via dip switch) with 1:1 split open collector signal output.
G680-PGD	Differential signal input (for line drive output encoders) with U V W differential signal with 1:1 split open collector signal output.
G680-PGR	Rotary Transformer PG Card for rotary transformer encoders with 1:1 split differential signal output.
G680-PGS	Sine-cosine PG card for sine-cosine encoders with 1:1 split differential signal output.
G680-3TEMP	Detects external motor or equipment temperature and protects against over-temperature, suitable for PT100 or KTY84 temperature sensors.

**2. Open collector PGO (G680-PGO) instructions for use:**

A	B	Z	15V	COM	COM	OA	OB	COM
---	---	---	-----	-----	-----	----	----	-----

Appendix C: Figure 2 G680-PGC Terminal Diagrams

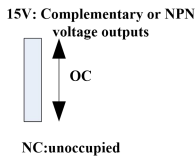

Appendix C: Figure 3 G680-PGC Jumper Switch Diagrams

**Open Collector Input PGO Card Terminal Function Description:**

Terminal identification	Function	Responsiveness	Maximum current	Note
-------------------------	----------	----------------	-----------------	------

15V,COM	Encoder operating power supply	--	100mA	--
A B Z	Encoder A B Z signal input interface	0 to 100kHz	--	Open collector signal or complementary (push-pull) output signal or NPN voltage output signal
OA, COM OB, COM	1:1 A B signal output	0 to 100kHz	100mA	Open Collector Signal
Remarks: 1. PG Card 1 can only be applied to asynchronous machines; 2. compatible with complementary output, NPN voltage output encoder, through the jumper switch switch, see Figure 3.				

**3. The differential signal input PGD card (G680-PGD) instructions for use:**

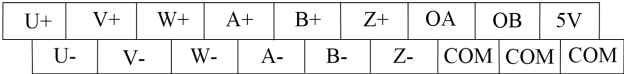

Appendix B: Figure 4 G680-PGD Terminal Diagrams

**Differential Signal Input PGD Card Terminal Function Description:**

Terminal identification	Function	Responsiveness	Maximum current	Note
5V,COM	Encoder operating power supply	--	100mA	--
A+,A- B+,B- Z+,Z-	Encoder A B Z differential signal input interface	0 to 200kHz	--	--
U+,U- V+,V- W+,W-	Differential signal input interface for encoder U V W position	0 to 20kHz	--	When used as a normal encoder for asynchronous machines, this terminal is not wired.
OA, COM OB, COM	1:1 A B signal output	0 to 200kHz	100mA	Open Collector Signal

Remarks:

1. Applicable to encoders in the form of line drive output;
2. PGD card can be applied to asynchronous machine, access to differential signal encoder, at this time, U V W terminal is not wired;
3. The PGD card can also be used in synchronous machines. It can be connected to a U V W encoder with rotor pole detection and requires that the number of poles of the U V W encoder is the same as that of the synchronous machine, and that only the same number of poles can be used in conjunction with it.

5. Instructions for using the resolver input PGR card (G680-PGR):

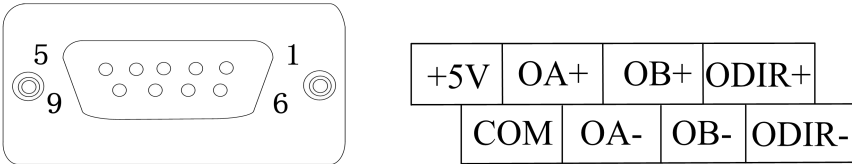

Appendix B: Figure 5 G680-PGR Terminal Diagrams

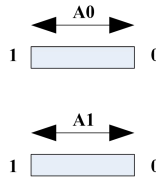

Appendix B: Figure 6 G680-PGR jumper switch diagram (when A0 A1 are both "0" (factory mode), output position signal, when A0 A1 are both "1", configuration mode, at this time, the excitation frequency can be changed through the function parameters)

Description of the function of the rotary transformer input PGR card terminal (DB9 connector):

Terminal identification	Function	Responsiveness	Note
1	EXC-	--	Rotary Transformer Excitation Negative
2	EXC+	--	Rotary Transformer Excitation Positive

3	SIN+	0 to 20kHz	Rotary transformer feedback SIN positive
4	SIN-		Rotary transformer feedback SIN negative
5	COS+		Rotary transformer feedback COS positive
6-8	--	--	NC (computing)
9	COS-	0 to 20kHz	Rotary Transformer Feedback COS Negative
OA+,OA- OB+,OB- ODIR+,ODIR-	Differential signal output	0 to 500kHz	1. A B speed differential signal output; 2. DIR direction logic output, high (1) indicates the rotation of the angle increase.
<p>Remarks:</p> <ol style="list-style-type: none"> <li>1. Applicable to resolver encoder;</li> <li>2. PGR card excitation frequency: 10KHZ, excitation voltage VRMS: 7V, resolution: 12 bits.</li> <li>3. Jumper switches A0 and A1 output position signals (factory mode) when they are both at low voltage level (0), and are in configuration mode when they are both at high level (1).</li> </ol>			

**6. Instructions for the use of the sine-cosine PGS card (G680-PGS):**

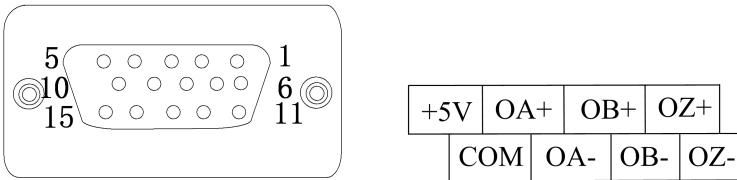

**Appendix B: Figure 7 G680-PGS Terminal Diagrams**

**Description of Sine Cosine PGS Card Terminal Functions (DB15 Connector)**

Terminal identification	Function	Responsiveness	Note
1	B-	0 to 80kHz	Sine cosine encoder B signal negative
2	empty-handed	--	--
3	Z+	0 to 80kHz	Positive cosine encoder Z signal

4	Z-	0 to 80kHz	Sine cosine encoder Z signal negative
5	A+	0 to 80kHz	Positive cosine encoder A signal
6	A-	0 to 80kHz	Sine cosine encoder A signal negative
7	COM	--	Sine-cosine encoder power supply ground
8	B+	0 to 80kHz	Sine cosine encoder B signal positive
9	+5V	--	Power supply for sine-cosine encoders
10	C+	0 to 80kHz	Cosine encoder C signal positive
11	C-	0 to 80kHz	Cosine Encoder C Signal Negative
12	D+	0 to 80kHz	Positive cosine encoder D signal
13	D-	0 to 80kHz	Sine cosine encoder D signal negative
14,15	NC	--	--
OA+,OA- OB+,OB- OZ+,OZ-	1:1 A B Z differential signal outputs	0 to 80kHz	Differential signal output
<p>Remarks:</p> <ol style="list-style-type: none"> <li>1. Suitable for SIN/COS (sine-cosine) encoder type ERN1387;</li> <li>2. Input signal interface adopts DB15 interface.</li> </ol>			

### Appendix C Version Change Record

Date	Changed version	Changes
2024-04	V2.0	Initial version of the user manual.
2024-05	V2.0	<ol style="list-style-type: none"> <li>1. Dual display digital tube keypad first line display value (F7-29, F7-30) and the second display value (E0-01 bit setting) can be set freely, and can be set to a unique value;</li> <li>2. n0-00 = 11 constant pressure water supply application macro can display three quantities at the same time: set pressure, feedback pressure, operating frequency;</li> <li>3. Changes in naming rules: Changes in accordance with the principle of rounding, the original single-phase 220V "3S" was changed to "2S". The original three-phase 220V "3T" was changed to "2T".</li> </ol>
2024-07	V2.1	<ol style="list-style-type: none"> <li>1. Increase E2-12 VF high carrier enable, the maximum carrier can reach 14K;</li> <li>2. Add monitoring parameter U1-74 Effective carrier;</li> <li>3. 2.2kW rated current changed from 5.1A to 6.5A;</li> <li>4. Increase Fd-12 torque control accuracy mode selection: Mode 2 is upgraded from <math>\pm 12\%</math> to <math>\pm 5\%</math> compared with Mode 1;</li> <li>5. Add synchronous motor related function code parameter: F4-57 Initial position compensation angle;</li> <li>6, Chapter 5 to add 630S synchronous motor fault code: Err45 (permanent magnet synchronous initial position recognition fault), Err48 (inverse phase electric potential recognition error fault);</li> <li>7. Chapter VI adds the no~n1 group of communication addresses;</li> <li>8, increase F8-07 communication current resolution 0:0.01A, 1:0.1A.</li> </ol>
2024-12	V2.2	<ol style="list-style-type: none"> <li>1. Increase F8-08 communication reading frequency resolution 0: controlled by F0-20 1: 0.1 Hz 2: 0.01 Hz;</li> <li>2. The original F6-31 AO output selection through the jumper switch to select the voltage type or current type, has nothing to do with the function code parameter, the parameter is changed to reserved.</li> </ol>

## Warranty

Our company solemnly promises that since the date when the user buys the product from our company (hereinafter referred to as the manufacturer), the user enjoys the following after-sales service of the product.

1. This product is accompanied by a complimentary 15-month warranty from the manufacturer starting from the date of purchase, with an extension to 18 months for products exported overseas or non-standard machines based on their serial number.
2. This product from the user from the date of purchase from the manufacturer within one month of the occurrence of quality problems, the manufacturer package refund, replacement, repair.
3. This product from the user from the date of purchase from the manufacturer within three months of the occurrence of quality problems, the manufacturer package replacement, package repair.
4. This product carries a 6-month warranty at the place of purchase from the date of purchase by the user from the manufacturer for export overseas.
5. This product is entitled to paid lifetime service from the date of purchase by the user from the manufacturer.
6. Disclaimer: Product failures caused by the following reasons are not covered by the manufacturer's 15-month free warranty service commitment:
  - (1) The user does not follow the procedures listed in the User's Manual for proper operation;
  - (2) Users without communicating with the manufacturer to repair the product or unauthorized modification caused by product failure;
  - (3) Product malfunction caused by the user using the product beyond the standard use range of the product;
  - (4) Due to the user's poor use of the environment leading to abnormal aging or failure of the product device;
  - (5) Damage to the product due to force majeure such as earthquakes, fires, wind and water damage, lightning strikes, abnormal voltages or other natural disasters;
7. The manufacturer reserves the right not to provide warranty service under the following conditions:
  - (1) When the manufacturer's brand, trademark, serial number, nameplate, or other markings expressed in the product are destroyed or illegible;
  - (2) When the user fails to pay for the goods in accordance with the Purchase and Sales Contract signed by both parties;
  - (3) When the user intentionally conceals from the manufacturer's after-sales service provider unit any undesirable use of the product during installation, wiring, operation, maintenance, or other processes.



### Warranty Card

Customer:		
Address:		
Contact:	Tel/Fax:	
Model:		
SN:		
Date of purchased:		Date of fault occurred:
Motor power:		Equipment matched:
Whether to use the braking unit function <input type="checkbox"/> YES <input type="checkbox"/> NO	Whether any unusual noise when there is a malfunction <input type="checkbox"/> YES <input type="checkbox"/> NO	Whether smoke when there is a malfunction <input type="checkbox"/> YES <input type="checkbox"/> NO
Malfunction description:		

**Note: Please send this card with the faulty product to our company, thanks!**



### Certificate of Conformity

Inspector:



Production Date:

The product has passed by our Quality Control and Quality Assurance departments.

Ensuring that its performance parameters meet the standards specified in the accompanying User Manual, thus enabling it to be shipped.